

Line Strainer 4005

Dimensions and Weights

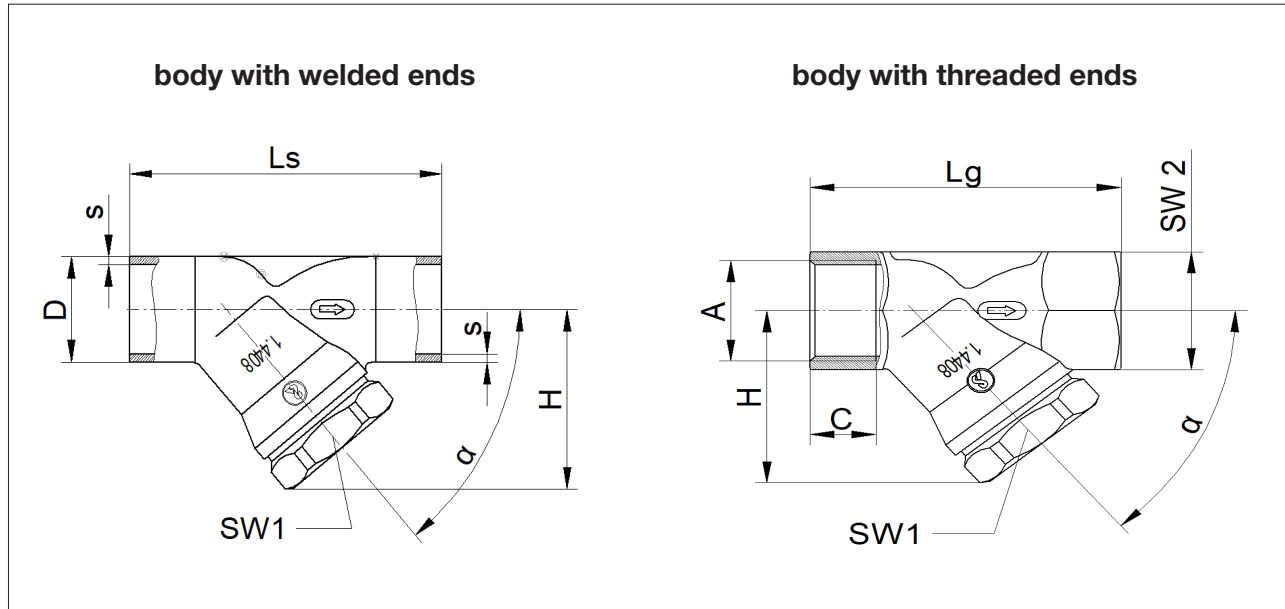

Angle seat body



Size	with welding ends acc. ISO			with G-thread				Alpha	H	SW1	Cv value	Weight lbs
	D	s	Ls	A	C	SW2	Lg					
3/8"	-	-	-	3/8"	0.47	0.91	2.36	50°	1.61	1.06	1.2	0.5
1/2"	0.84	0.08	3.15	1/2"	0.59	0.98	2.56	50°	1.59	1.06	2.9	0.5
3/4"	1.06	0.09	3.54	3/4"	0.64	1.22	2.13	50°	1.89	1.26	5.8	0.5
1"	1.33	0.1	3.94	1"	0.75	1.54	2.48	50°	2.26	1.42	9.9	1
1 1/4"	1.68	0.1	4.33	1 1/4"	0.84	1.89	2.91	50°	2.78	1.42	16.8	2
1 1/2"	1.9	0.1	4.72	1 1/2"	0.84	2.17	3.13	50°	2.87	1.42	22.6	2.5
2"	2.37	0.11	5.91	2"	1.01	2.68	3.78	50°	3.48	1.42	34.8	3.5
2 1/2"	3	0.11	7.09	2 1/2"	1.19	3.35	4.85	50°	4.37	1.42	60.3	7.5
3"	3.5	0.13	8.66	3"	1.32	3.94	5.99	45°	4.94	1.61	96.3	12.1

Dimensions in inch

Line Strainer 4005

Dimensions and Weights

Rectangular body

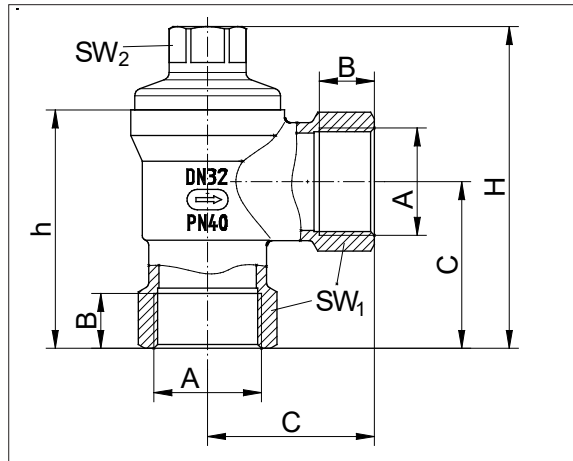

Size	with G-thread		with NPT-thread		C	SW1	SW2	h	H	Weight lbs
	A	B	A	B						
1/2"	G 1/2"	0.59	NPT 1/2"	0.57	1.61	0.98	1.26	2.52	2.95	3
3/4"	G 3/4"	0.64	NPT 3/4"	0.59	1.61	1.26	1.42	2.6	3.48	3.5
1"	G 1"	0.75	NPT 1"	0.7	1.61	1.61	1.42	2.66	3.76	4.5
1 1/4"	G 1 1/4"	0.84	NPT 1 1/4"	0.72	2.56	1.97	1.06	3.66	4.94	5
1 1/2"	G 1 1/2"	0.84	NPT 1 1/2"	0.72	2.56	2.17	1.42	3.98	5.51	7.5
2"	G 2"	1.01	NPT 2"	0.72	2.56	2.68	1.42	4.57	6.56	11.5

Dimensions in inch

Flanged body

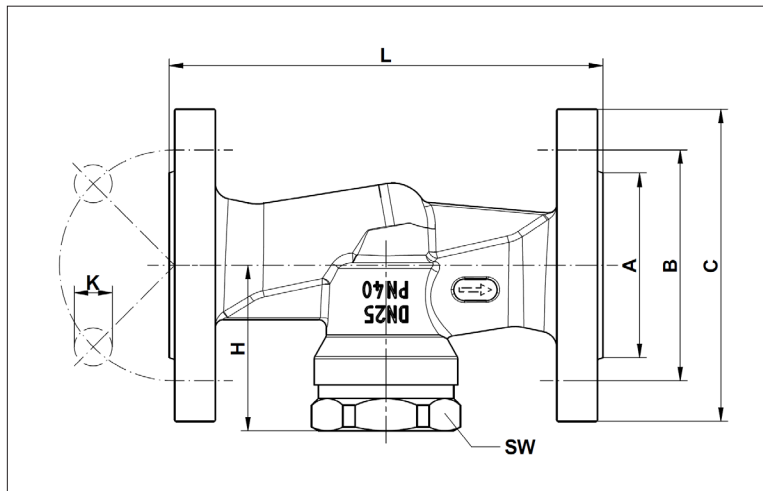

Size	Flanges acc. EN 1092-1; Face to face dimension acc. EN 558-1						Flanges acc. ASME B16.5; Face to face dimension acc. ANSI/ISA-75.08.01						H	SW	Weight [lbs]
	L	C	B	A	N (Number of holes)	K	L	C	B	A	N (Number of holes)	K			
1/2"	5.12	3.74	2.56	1.77	4	0.55	7.24	3.5	2.38	1.38	4	0.62	1.73	1.26	8.4
3/4"	5.91	4.13	2.95	2.28	4	0.55	7.24	3.88	2.75	1.69	4	0.62	2.4	1.42	8.4
1"	6.3	4.53	3.35	2.68	4	0.55	7.24	4.25	3.12	2	4	0.62	2.83	1.42	9.7
1 1/4"	7.09	5.51	3.94	3.07	4	0.71	7.87	4.62	3.5	2.5	4	0.62	3.23	1.06	13.5
1 1/2"	7.87	5.91	4.33	3.46	4	0.71	8.74	5	.88	2.88	4	0.62	3.9	1.42	17.9
2"	9.06	6.5	4.92	4.02	4	0.71	10	6	4.75	3.62	4	0.75	5.16	1.42	25.6
2 1/2"	11.42	7.28	5.71	4.8	8	0.71	-	-	-	-	-	-	5.59	-	44.1
3"	12.2	7.87	6.3	5.43	8	0.71	-	-	-	-	-	-	7.01	-	58

Dimensions in inch

Text and pictures are not binding. We reserve the right to alter the equipment.