

DN 15 up to DN 80

Pneumatically operated angle seat valve for the control of neutral, slightly aggressive and highly aggressive media.

- Compact design
- Unaffected by lightly contaminated media
- For temperatures from -100°C up to +220°C
- Working pressure up to 40 bar
- Versatile actuator options



Technical Information

Gehäusewerkstoff	Edelstahl 1.4408
Nennweiten	DN 15 bis DN 80
Anschluß:	Flansch nach DIN EN 1092-1: PN40 Flansch nach ASME B16.5: ANSI #150, ANSI #300
Nennndruck	PN 40 / ANSI #150 / ANSI #300
Medientemperatur* (Standardausführung) mit Metallhaube mit Kunststoffhaube mit Membranantrieb Umgebungstemperatur	-30°C bis +170°C opt.-100°C bis +220°C -30°C bis +135°C -30°C bis +200°C opt.-100°C bis +220°C -30°C bis +60°C
Viskosität des Mediums	maximal 600 mm ² /s (600cSt, 80°E)
Vakuum	maximal 0,001 bar abs
Betriebsdrücke	Siehe Tabellen und Diagramme, Begrenzung für gefährliche Gase nach Druck- geräterichtlinie 2014/68/EU (Kategorie I): PS x DN < 1000
Betriebsdruck bei tottraumfreier Aus- führung	maximal 12 bar
Klassifizierung ISO15848-1	ISO FE BH-CC3-SSA1-t(-30°C, +80°C) Prüf- druck 40 bar
Leckage nach EN 12266-1	Leckageklasse A
Baulänge	L nach DIN EN 558-92 (alt: DIN 3202-F3)

Options and accessories

- Stroke limitation
- Manual emergency operation
- El. position indicator with inductive or mechanical limit switches
- Solenoid valves
- AS-I control head
- Oil- and greasefree version, PTFE-free version, siliconfree version
- Versions for oxygen or ozon applications
- FDA-compliant version
- Version acc. regulation (EG) 1935/2004
- Offshore-version
- Mounting bracket for inductive limit switches
- Version for higher pilot pressures
- Version for under water use
- ...

Angle Seat Valve 7031

Build up and function

Spring closes

The function „spring closes“ may be applied closing against or closing with the flow. In the configuration closing with the flow the valve should only be used for gaseous fluids. If used for liquids, water hammers may occur.

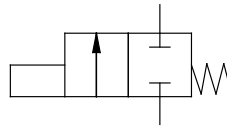

Removable position indicator

Bonnet can be rotated as required (compressed air connection)

Direct pressure control (with a pilot valve if required) actuation by air, water, mineral oil and other media

Head Section

Piston rod stainless steel

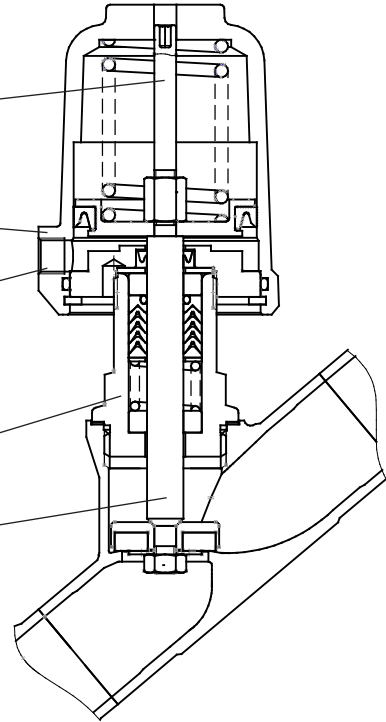

Spring opens

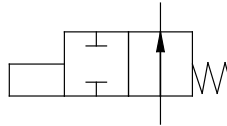

Bonnet material chrome plated brass, plastic, stainless steel or Aluminium

Exterior lip seal

Leak detector

PTFE packing, special version free or (packing underneath)

Seating seal in PTFE or other materials

body with various connection types

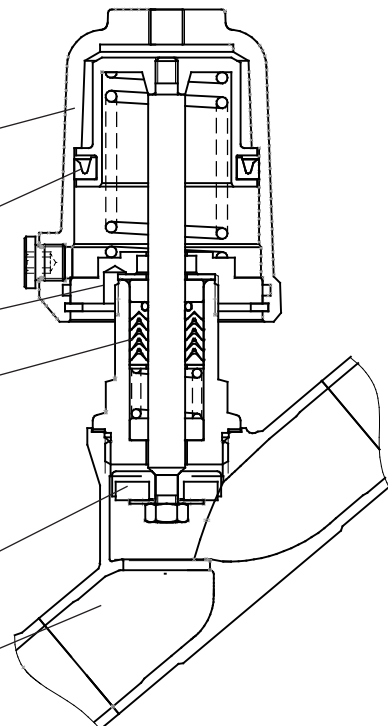

Pilot and operating pressures

Function „spring closes“, closing against flow

Nominal size	Version	actuator	Springs	max. differential pressure			pilot pressure [bar]
				PTFE	PEEK 7	PEEK 8	

DN15	Standard	D50	1	21,5	-	17	3,5 - 10	
			0	2	34,5	11,5	30	4,5 - 10
			0	3	40	26	40	5,7 - 10
		D80	1	40	40	40	3,5 - 10	

DN20	Standard	D50	1	6,9	-	3,7	3,5 - 10	
			0	2	12,5	-	9,6	4,5 - 10
			0	3	19	2,9	15,5	5,7 - 10
		D80	1	40	25	38	3,5 - 10	
			2	40	38,5	40	4,4 - 10	
			3	40	40	40	5,6 - 10	

DN25	Standard	D50	1	2,4	-	-	3,5 - 10	
			0	2	5,7	-	3,2	4,5 - 10
			0	3	9,1	-	6,6	5,7 - 10
		D80	1	22	9,9	19,5	3,5 - 10	
			2	30	17,5	27,5	4,4 - 10	
			3	39	27	36,5	5,6 - 10	
		D125	1	19	6,7	16,5	1,3 - 10	
			2	40	28	38	2,2 - 10	
			3	40	40	40	3,1 - 10	

DN32	Standard	D50	1	1	-	-	3,5 - 10	
			0	2	3,1	-	1,1	4,5 - 10
			0	3	5,1	-	3,1	5,7 - 10
		D80	1	12,5	2,7	10,5	3,5 - 10	
			2	17	7,3	15	4,4 - 10	
			3	22	12,5	20,5	5,6 - 10	
		D125	1	10,5	1,1	8,9	1,3 - 10	
			2	23,5	14	21,5	2,2 - 10	
			3	33,5	24	31,5	3,1 - 10	
			4	39	29,5	37	4,0 - 10	
	D250	8	40	40	40	2,7 - 6		
		0	2	40	40	4,5 - 10		
	pressure balanced	D80	1	40	40	40	3,5 - 10	
			0	2	40	40	4,4 - 10	

DN40	Standard	D50	2	1,9	-	-	4,5 - 10	
			0	3	3,3	-	1,6	5,7 - 10
			0	3	3,3	-	1,6	5,7 - 10
		D80	1	7,9	-	6,2	3,5 - 10	
			2	11	2,8	9,3	4,4 - 10	
			3	14	6,2	12,5	5,6 - 10	
		D125	1	7	-	5,3	1,3 - 10	
			2	15,5	7,4	14	2,2 - 10	
			3	22	14	20,5	3,1 - 10	
	d16	0	4	25	16,5	23,5	4,0 - 10	
		D250	8	32	24	30	2,7 - 6	
			0	12	40	36,5	40	3,7 - 6
	pressure balanced	D50	3	40	-	40	5,7 - 10	
			D80	1	40	-	40	3,5 - 10
0	2	40		40	40	4,4 - 10		

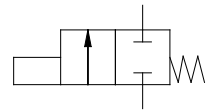
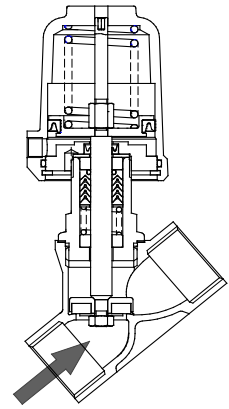

 = Standard spring configuration
 d16: reinforced design with 16mm piston rod
 PEEK 7: Seating seal made of PEEK for use below 160°C
 PEEK 8: Seating seal made of PEEK for use above 160°C
 For soft seals such as EPDM, FKM, NBR or Vulkolan the same values as with PTFE are valid

Pilot and operating pressures

Function „spring closes“, closing against flow

Nominal size	Version	actuator	Springs	max. differential pressure			pilot pressure [bar]
				PTFE	PEEK 7	PEEK 8	

DN50	Standard	D50	2	1	-	-	4,5 - 10
			3	1,9	-	-	5,7 - 10
		D80	1	4,1	-	2,8	3,5 - 10
			2	5,9	-	4,6	4,4 - 10
		D125	3	7,8	1,2	6,5	5,6 - 10
			1	3,8	-	2,5	1,3 - 10
	d16	D125	2	9	2,4	7,6	2,3 - 10
			3	12,5	6	11	3,1 - 10
		D250	4	13	6,8	12	4,0 - 10
	pressure balanced	D250	8	19,5	13	18	2,7 - 6
			12	27,5	21	26	3,7 - 6
		D50	2	31,5	-	-	4,5 - 10
			3	40	-	-	5,7 - 10
		D80	2	40	11	40	4,4 - 10
3			40	40	40	5,6 - 10	
D125	2	40	40	40	2,2 - 10		

DN65	Standard	D80	3	4,2	-	3,2	5,6 - 10
			1	1,9	-	-	1,3 - 10
		D125	2	4,8	-	3,9	2,2 - 10
	3		7	2	6	3,1 - 10	
	d16	D125	3	7	2	6	3,1 - 10
			4	7,5	2,5	6,5	4,0 - 10
		D250	8	11	6	10	2,7 - 6
			12	15	10	14	3,7 - 6
	pressure balanced	D50	2	21	-	-	4,5 - 10
			2	25	-	25	4,4 - 10
D125		2	25	-	25	2,2 - 10	
	3	25	25	25	3,1 - 10		

DN80	d16	D125	3	4,7	-	3,9	3,2 - 10
			4	5	-	4,2	4,0 - 10
		D250	8	7,5	3,4	6,7	2,7 - 6
			12	10,5	6,4	9,7	3,7 - 6
	pressure balanced	D80	2	25	-	18	4,6 - 10
			3	25	-	25	5,6 - 10
		D125	2	25	-	25	2,2 - 10
3	25		6,1	25	3,2 - 10		

	= Standard spring configuration
d16: reinforced design with 16mm piston rod	
PEEK 7: Seating seal made of PEEK for use below 160°C	
PEEK 8: Seating seal made of PEEK for use above 160°C	
For soft seals such as EPDM, FKM, NBR or Vulkolan the same values as with PTFE are valid	

Angle Seat Valve 7031

Pilot and operating pressures

Function „spring opens“, closing against flow

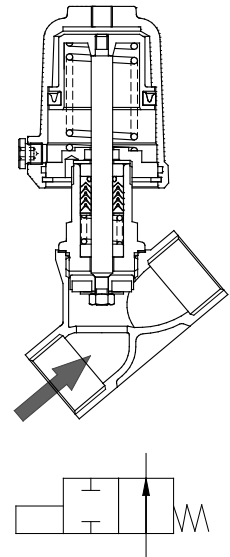

Seating seal PTFE, EPDM, FKM, NBR or Vulkolan

Nominal size	Version	Actuator	Max. differential pressure [bar] at available pilot pressure [bar]																
			2	2,5	3	3,5	4	4,5	5	5,5	6	6,5	7	7,5	8	8,5	9	9,5	10
DN15	Standard	D50	0	0	6,6	13,5	20,5	27,5	34,5	40	40	-	-	-	-	-	-	-	-
		D80	40	40	-	-	-	-	-	-	-	-	-	-	-	-	-	-	-
DN20	Standard	D50	0	0	0,6	4,1	7,6	11	14,5	18	21	24,5	28	31,5	35	38,5	40	40	-
		D80	19,5	28,5	37,5	40	-	-	-	-	-	-	-	-	-	-	-	-	-
DN25	Standard	D50	0	0	0	1,2	3,3	5,3	7,4	9,5	11,5	13,5	15,5	17,5	19,5	21,5	23,5	26	28
		D80	10	15,5	21	26,5	32	37,5	40	40	-	-	-	-	-	-	-	-	-
DN32	Standard	D50	0	0	0	0,3	1,6	2,8	4,1	5,4	6,7	8	9,3	10,5	11,5	13	14	15,5	16,5
		D80	5,6	9	12	15,5	19	22,5	25,5	29	32,5	35,5	39	40	-	-	-	-	-
		D125	24,5	32,5	40	-	-	-	-	-	-	-	-	-	-	-	-	-	-
DN40	Standard	D50	0	0	0	0	0,8	1,7	2,6	3,5	4,4	5,3	6,2	7,1	8	8,9	9,8	10,5	11,5
		D80	3,4	5,8	8,1	10,5	12,5	15	17,5	19,5	22	24,5	26,5	29	31,5	34	36	38,5	40
		D125	16,5	22	28	34	39,5	40	-	-	-	-	-	-	-	-	-	-	-
DN50	Standard	D50	0	0	0	0	0,3	0,8	1,4	2	2,6	3,2	3,7	4,3	4,9	5,5	6	6,6	7,2
		D80	1,7	3,2	4,7	6,2	7,7	9,2	10,5	12	13,5	15	16,5	18	19,5	21	22,5	24	25,5
		D125	10	13,5	17,5	21	25	28,5	32,5	36	40	-	-	-	-	-	-	-	-
DN65	Standard	D80	0,6	1,5	2,4	3,2	4,1	4,9	5,8	6,7	7,5	8,4	9,2	10	10,5	11,5	12,5	13,5	14
		D125	5,5	7,6	9,7	11,5	14	16	18	20	22	24,5	25	-	-	-	-	-	-
	d16	D125	5,4	7,5	9,6	11,5	13,5	15,5	18	20	22	24	25	-	-	-	-	-	-
DN80	Standard*	D80	0,3	0,9	1,5	2,1	2,7	3,3	3,9	4,5	5,1	5,7	6,3	6,9	7,5	8,1	8,7	9,3	9,9
		D125	3,7	5,2	6,6	8,1	9,6	11	12,5	14	15,5	16	-	-	-	-	-	-	-
	d16	D125	3,6	5,1	6,5	8	9,5	10,5	12	13,5	15	16,5	18	19,5	21	22,5	24	25	-

d16: reinforced design with 16mm piston rod

Actuator D50: max. pilot pressure 1 bar above the required pilot pressure

Actuator D80: max. pilot pressure 0,8 bar above the required pilot pressure

Actuator D125 and D250: max. pilot pressure 0,5 bar above the required pilot pressure

Pilot and operating pressures

Function „spring opens“, closing against flow

Seating seal PEEK-8

Nominal size	Version	Actuator	Max. differential pressure [bar] at available pilot pressure [bar]																
			2	2,5	3	3,5	4	4,5	5	5,5	6	6,5	7	7,5	8	8,5	9	9,5	10
DN15	Standard	D50	0	0	2	9	16	23	30	37	40	40	-	-	-	-	-	-	-
		D80	39,5	40	-	-	-	-	-	-	-	-	-	-	-	-	-	-	-
DN20	Standard	D50	0	0	0	0,9	4,3	7,8	11	14,5	18	21,5	25	28,5	32	35,5	39	40	40
		D80	16	25	34	40	40	-	-	-	-	-	-	-	-	-	-	-	-
DN25	Standard	D50	0	0	0	0	0,8	2,9	4,9	7	9	11	13	15	17	19	21	23,5	25,5
		D80	7,9	13	18,5	24	29,5	35	40	40	-	-	-	-	-	-	-	-	-
DN32	Standard	D50	0	0	0	0	0	0,9	2,2	3,4	4,7	6	7,3	8,6	9,9	11	12	13,5	15
		D80	3,7	7	10	13,5	17	20,5	23,5	27	30,5	34	37	40	40	-	-	-	-
		D125	22,5	30,5	39	40	-	-	-	-	-	-	-	-	-	-	-	-	-
DN40	Standard	D80	1,8	4,1	6,5	8,8	11	13,5	15,5	18	20,5	23	25	27,5	30	32	34,5	37	39
		D125	15	20,5	26,5	32	38	40	-	-	-	-	-	-	-	-	-	-	-
DN50	Standard	D80	0,3	1,9	3,4	4,9	6,4	7,9	9,4	11	12,5	14	15,5	17	18,5	20	21,5	23	24,5
		D125	8,8	12,5	16	20	23,5	27,5	31	35	38,5	40	-	-	-	-	-	-	-
DN65	Standard	D80	0	0,6	1,4	2,3	3,1	4	4,8	5,7	6,6	7,4	8,3	9,1	10	10,5	11,5	12,5	13
		D125	4,5	6,6	8,7	10,5	13	15	17	19	21	23,5	25	-	-	-	-	-	-
	d16	D250	5	9,3	13,5	18	22	25	-	-	-	-	-	-	-	-	-	-	-
DN80	d16	D80	0	0	0,5	1,1	1,7	2,3	2,9	3,5	4	4,6	5,2	5,8	6,4	6,9	7,5	8,1	8,7
		D125	2,8	4,3	5,7	7,2	8,6	10	11,5	13	14,5	15,5	17	18,5	20	21,5	23	24,5	25
		D250	3,2	6,2	9,2	12	15	18	21	24	25	-	-	-	-	-	-	-	-

Sitzdichtung PEEK-7

Nominal size	Version	Actuator	Max. differential pressure [bar] at available pilot pressure [bar]																
			2	2,5	3	3,5	4	4,5	5	5,5	6	6,5	7	7,5	8	8,5	9	9,5	10
DN15	Standard	D50	0	0	2	9	16	23	30	37	40	40	-	-	-	-	-	-	-
		D80	39,5	40	-	-	-	-	-	-	-	-	-	-	-	-	-	-	-
DN20	Standard	D50	0	0	0	0,9	4,3	7,8	11	14,5	18	21,5	25	28,5	32	35,5	39	40	40
		D80	16	25	34	40	40	-	-	-	-	-	-	-	-	-	-	-	-
DN25	Standard	D50	0	0	0	0	0,8	2,9	4,9	7	9	11	13	15	17	19	21	23,5	25,5
		D80	7,9	13	18,5	24	29,5	35	40	40	-	-	-	-	-	-	-	-	-
DN32	Standard	D50	0	0	0	0	0	0,9	2,2	3,4	4,7	6	7,3	8,6	9,9	11	12	13,5	15
		D80	3,7	7	10	13,5	17	20,5	23,5	27	30,5	34	37	40	40	-	-	-	-
		D125	22,5	30,5	39	40	-	-	-	-	-	-	-	-	-	-	-	-	-
DN40	Standard	D80	1,8	4,1	6,5	8,8	11	13,5	15,5	18	20,5	23	25	27,5	30	32	34,5	37	39
		D125	15	20,5	26,5	32	38	40	-	-	-	-	-	-	-	-	-	-	-
DN50	Standard	D80	0,3	1,9	3,4	4,9	6,4	7,9	9,4	11	12,5	14	15,5	17	18,5	20	21,5	23	24,5
		D125	8,8	12,5	16	20	23,5	27,5	31	35	38,5	40	-	-	-	-	-	-	-
DN65	Standard	D80	0	0,6	1,4	2,3	3,1	4	4,8	5,7	6,6	7,4	8,3	9,1	10	10,5	11,5	12,5	13
		D125	4,5	6,6	8,7	10,5	13	15	17	19	21	23,5	25	-	-	-	-	-	-
	d16	D250	5	9,3	13,5	18	22	25	-	-	-	-	-	-	-	-	-	-	-
DN80	d16	D80	0	0	0,5	1,1	1,7	2,3	2,9	3,5	4	4,6	5,2	5,8	6,4	6,9	7,5	8,1	8,7
		D125	2,8	4,3	5,7	7,2	8,6	10	11,5	13	14,5	15,5	17	18,5	20	21,5	23	24,5	25
		D250	3,2	6,2	9,2	12	15	18	21	24	25	-	-	-	-	-	-	-	-

Pilot and operating pressures

Function „spring closes“, closing with flow

- Angled seat valve closing with the flow, spring closes
- Use preferably for gaseous fluids
- With liquids waterhammers are possible

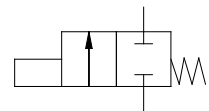
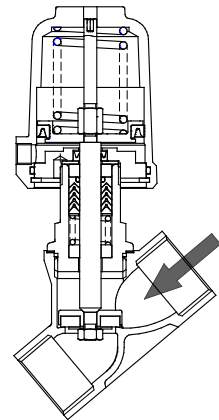

Seating seal PTFE, EPDM, FKM, NBR or Vulkolan

Nominal Size	Version	Actuator	Springs	Max. differential pressure [bar] at available pilot pressure [bar]																
				2	2,5	3	3,5	4	4,5	5	5,5	6	6,5	7	7,5	8	8,5	9	9,5	10
DN15	Standard	D50	Standard	0	5	21,5	38,5	40	40	40	40	40	40	40	40	40	40	40	40	40
DN20	Standard	D50	Standard	0	3,8	8,7	13,5	18	23	28	33	37,5	40	40	40	40	40	40	40	40
		D80	Standard	25,5	38,5	40	40	40	40	40	40	40	40	40	40	40	40	40	40	40
DN25	Standard	D50	Standard	0,2	2,7	5,2	7,7	10	12,5	15	17,5	20	22,5	25	27,5	30	32,5	33	33	33
		D80	Standard	13,5	20	26,5	33	33	33	33	33	33	33	33	33	33	33	33	33	33
DN32	Standard	D50	Standard	0,1	1,6	3	4,4	5,9	7,3	8,7	10	11,5	13	14,5	15,5	17	18,5	19	19	19
		D80	Standard	8	11,5	15,5	19	23	26,5	30,5	34	35	35	35	35	35	35	35	35	35
		D125	Standard	28,5	35	35	35	35	35	35	35	35	35	35	35	35	35	35	35	35
DN40	Standard	D50	Standard	0	0,5	1,4	2,4	3,4	4,3	5,3	6,3	7,2	8,2	9,2	10	11	12	13	13	13
		D80	Standard	2,6	5,1	7,7	10	12,5	15	17,5	20	22,5	23	23	23	23	23	23	23	23
		D125	Standard	12,5	18,5	23	23	23	23	23	23	23	23	23	23	23	23	23	23	23
	d16	D125	Standard	12	18,5	24,5	30,5	37	40	40	40	40	40	40	40	40	40	40	40	
DN50	Standard	D50	Standard	0	0,2	0,8	1,4	2	2,6	3,2	3,9	4,5	5,1	5,7	6,3	6,9	7,5	8	8	8
		D80	Standard	2	3,6	5,2	6,8	8,4	10	11,5	13	14,5	15	15	15	15	15	15	15	15
		D125	Standard	8,3	12	15	15	15	15	15	15	15	15	15	15	15	15	15	15	
	d16	D125	Standard	8,1	12	15,5	19,5	23,5	27,5	31	35	38	38	38	38	38	38	38	38	
DN65	Standard	D80	Standard	1,1	2	2,9	3,7	4,6	5,5	6,4	7,3	8,1	9	9,9	10,5	11,5	12	12	12	12
		D125	Standard	4,6	6,7	8,9	11	12	12	12	12	12	12	12	12	12	12	12	12	
	d16	D125	Standard	4,5	6,6	8,8	10,5	13	15	17	19,5	20	20	20	20	20	20	20	20	
DN80	Standard	D80	Standard	0,7	1,3	2	2,6	3,2	3,8	4,4	5	5,6	6,2	6,8	7,4	8	8,7	9	9	9
		D125	Standard	3,1	4,6	6,1	7,6	9	9	9	9	9	9	9	9	9	9	9	9	
	d16	D80	Standard	0,6	1,2	1,8	2,4	3	3,6	4,2	4,8	5,4	5,9	6,5	7,1	7,7	8,3	8,9	9,5	10
		D250	Standard	4,9	7,9	11	13	13	13	13	13	13	13	13	13	13	13	13	13	

d16: reinforced design with 16mm piston rod

Pilot and operating pressures

Function „spring closes“, closing with flow

Seating seal PEEK-8

Nominal Size	Version	Actuator	Springs	Max. differential pressure [bar] at available pilot pressure [bar]																
				2	2,5	3	3,5	4	4,5	5	5,5	6	6,5	7	7,5	8	8,5	9	9,5	10
DN15	Standard	D50	2	0	0	0	0	4	20,5	37,5	40	40	40	40	40	40	40	40	40	40
DN20	Standard	D50	2	0	0	1,1	6	10,5	15,5	20,5	25,5	30	35	40	40	40	40	40	40	40
		D80	1	0	0	1,8	14,5	27	40	40	40	40	40	40	40	40	40	40	40	40
		D125	1	30	33	33	33	33	33	33	33	33	33	33	33	33	33	33	33	33
DN25	Standard	D50	2	0	0	2,1	4,6	7,1	9,6	12	14,5	17	19,5	22	24,5	27	29,5	32	33	33
		D80	1	0	0	2,8	9,4	15,5	22,5	29	33	33	33	33	33	33	33	33	33	33
		D125	1	30	33	33	33	33	33	33	33	33	33	33	33	33	33	33	33	33
DN32	Standard	D50	2	0	0	1,3	2,7	4,1	5,6	7	8,5	9,9	11	12,5	14	15,5	17	18,5	19	19
		D80	1	0	0	2,6	6,4	10	13,5	17,5	21,5	25	29	32,5	35	35	35	35	35	35
		D125	1	18	27	35	35	35	35	35	35	35	35	35	35	35	35	35	35	35
DN40	Standard	D80	1	0	0	2,4	5	7,5	10	12,5	15	17,5	20	22,5	23	23	23	23	23	23
		D125	2	3,2	9,5	15,5	22	23	23	23	23	23	23	23	23	23	23	23	23	23
	d16	D125	2	3	9,2	15	21,5	27,5	34	40	40	40	40	40	40	40	40	40	40	40
DN50	Standard	D80	2	0	0	0,3	1,9	3,5	5,1	6,7	8,2	9,8	11	13	14,5	15	15	15	15	15
		D125	2	2,9	6,8	10,5	14,5	15	15	15	15	15	15	15	15	15	15	15	15	15
	d16	D125	2	2,7	6,6	10,5	14	18	22	26	29,5	33,5	37,5	38	38	38	38	38	38	38
		D250	6	12,5	20,5	28,5	36,5	38	38	38	38	38	38	38	38	38	38	38	38	38
DN65	Standard	D125	2	1,5	3,7	5,9	8	10	12	12	12	12	12	12	12	12	12	12	12	12
		D125	2	1,4	3,6	5,7	7,9	10	12	14	16,5	18,5	20	20	20	20	20	20	20	20
	d16	D250	6	7,1	11,5	16	20	20	20	20	20	20	20	20	20	20	20	20	20	20
DN80	d16	D125	2	1	2,5	3,9	5,4	6,9	8,4	9,9	11	12,5	13	13	13	13	13	13	13	13
		D250	6	4,9	7,9	11	13	13	13	13	13	13	13	13	13	13	13	13	13	13

Seating seal PEEK-7

Nominal Size	Version	Actuator	Springs	Max. differential pressure [bar] at available pilot pressure [bar]																
				2	2,5	3	3,5	4	4,5	5	5,5	6	6,5	7	7,5	8	8,5	9	9,5	10
DN15	Standard	D50	2	0	0	0	0	4	20,5	37,5	40	40	40	40	40	40	40	40	40	40
DN20	Standard	D80	1	0	0	1,8	14,5	27	40	40	40	40	40	40	40	40	40	40	40	40
		D125	1	40	40	40	40	40	40	40	40	40	40	40	40	40	40	40	40	40
DN25	Standard	D80	1	0	0	2,8	9,4	15,5	22,5	29	33	33	33	33	33	33	33	33	33	33
		D125	1	30	33	33	33	33	33	33	33	33	33	33	33	33	33	33	33	33
DN32	Standard	D80	2	0	0	1,2	5	8,8	12,5	16	20	23,5	27,5	31	35	35	35	35	35	35
		D125	1	18	27	35	35	35	35	35	35	35	35	35	35	35	35	35	35	35
DN40	Standard	D80	2	0	0	0,8	3,3	5,8	8,3	10,5	13	15,5	18	20,5	23	25,5	28	30,5	33	33
		D125	2	3,2	9,5	15,5	22	23	23	23	23	23	23	23	23	23	23	23	23	23
	d16	D125	2	3	9,2	15	21,5	27,5	34	40	40	40	40	40	40	40	40	40	40	40
DN50	Standard	D125	2	2,9	6,8	10,5	14,5	15	15	15	15	15	15	15	15	15	15	15	15	15
		D125	2	2,7	6,6	10,5	14	18	22	26	29,5	33,5	37,5	38	38	38	38	38	38	38
	d16	D250	6	12,5	20,5	28,5	36,5	38	38	38	38	38	38	38	38	38	38	38	38	38
DN65	Standard	D125	3	0	1,5	3,7	5,9	8	10	12	12	12	12	12	12	12	12	12	12	12
		D125	3	0	1,4	3,6	5,7	7,9	10	12	14	16,5	18,5	20	20	20	20	20	20	20
	d16	D250	6	7,1	11,5	16	20	20	20	20	20	20	20	20	20	20	20	20	20	20
DN80	d16	D125	2	0	1	2,5	3,9	5,4	6,9	8,4	9,9	11	12,5	13	13	13	13	13	13	13
		D250	6	4,9	7,9	11	13	13	13	13	13	13	13	13	13	13	13	13	13	13

d16: reinforced design with 16mm piston rod

PEEK 7: Seating seal made of PEEK for use below 160°C

PEEK 8: Seating seal made of PEEK for use above 160°C

Ordering Number System

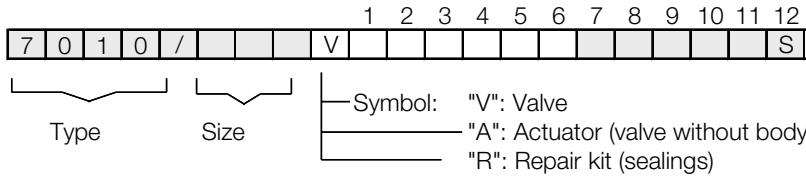

1 - 6 : Please quote all 6 sections.

7 - 12: Quote only if required.

1.	Body type	2.	Connection	3.	Body material	4.	Seating seal	5.	Pilot function	6.	Actuator
2	angle seat flange bodied valve	9	Angle Seat Flanged Valve, acc. DIN EN 1092-1 installation length acc. DIN 3202 F3	2	stainless steel 1.4408	0	PTFE	0	NC (closing with flow)	0	piston Ø50mm
						1	FKM (Viton)	1	NC (closing against flow)	1	piston Ø80mm
						2	EPDM	2	NO (closing against flow)	2	piston Ø125mm
						3	NBR	3	Universal, double acting	C	diaphragm actuator D250mm
		C	angle seat flange bodied valve acc. ANSI 150			7	PTFE with 25% glass fibre	5	spring closes, pressure balanced (closing against flow)	K	plastic bonnet (piston Ø50mm)
		F	angle seat flange bodied valve acc. ANSI 300			8	PEEK for applications above 160°C[320°F]	7	spring opens pressure balanced (closing against flow)	M	plastic bonnet (piston Ø80mm)
7.	Springs	8.	Head section material	9.	Packing	10.	Temperature version	11.	Accessories	12.	Special versions
-	standard	-	standard	-	standard	-	Standard	-	no accessories	S	further special versions
1	1 spring	K	reinforced design	2	packing underneath	H	high temperature version	1	electrical position indicator with one switch	M	position indicator with cable bushing
2	2 springs					W	low temperature version down to -40°C (-40°F)	2	electrical position indicator with two switches	N	position indicator with plug connection
3	3 springs						ambient, -50°C (-58°F) fluid temperature	3	manual emergency operation		
T	6 springs (D250)							4	manual override		
W	8 springs (D250)							5	stroke limitation		
Y	12 springs (D250)							6	pilot valve DN 2, 230 V AC		
								7	pilot valve DN 2, 24 V DC		
								K	electr. position indicator compact		
								M	position indicator with two ind. switch 10 - 36 V DC (PNP)		
								P	position indicator with one ind. switch 10 - 36 V DC (PNP)		
								T	position indicator compact, inductive 10 - 30 V DC (PNP)		

Ordering example:

7010/050V2920212- - -5

Nominal size 50 mm, angle seat flange valve, flange acc. EN 1092-1 PN40, stainless steel body, PTFE seatmaterial, N.C., actuator size 80 mm, two springs, stroke limitation.

Angle Seat Valve 7031

standard design

Dimensions and Weights

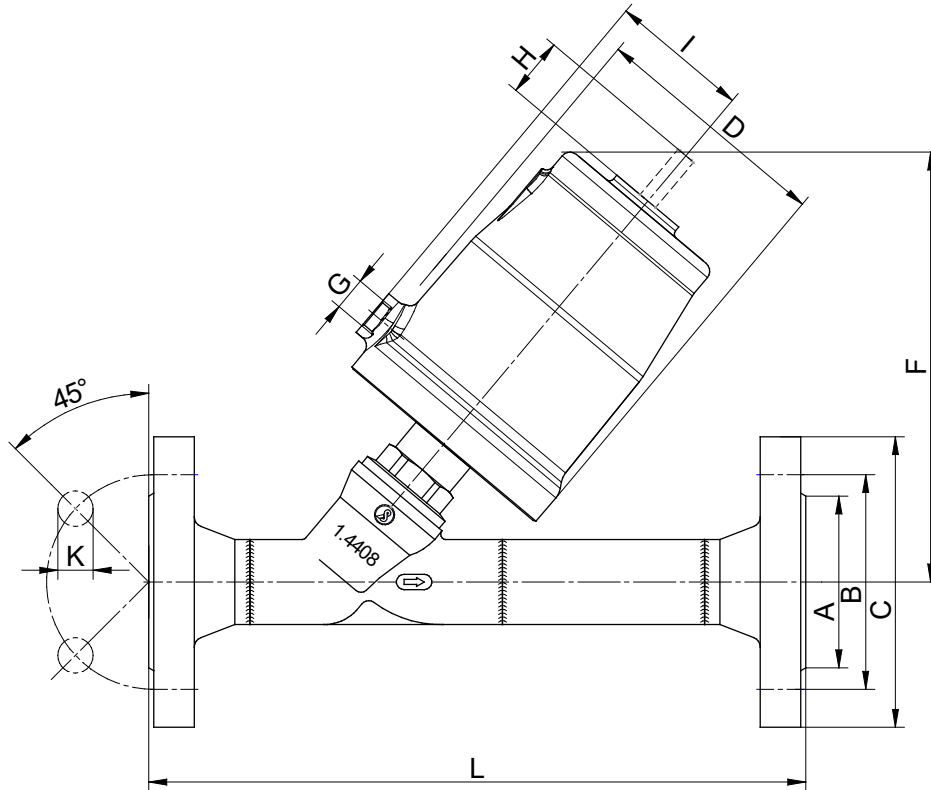

Normally closed

** <= 45° for DN65 and DN80

DN	piston Ø	A		B		C		D	F	G	H (stroke)	I	K		L*	M	N number of bores	Kvs- value	Weight (kg)
		PN40 (DN65 PN16)	ANSI #150	PN40	ANSI #150	PN40	ANSI #150						PN40	ANSI #150					
15	50	45	34,9	65	60,3	95	90	62	125	G1/8	7	34,5	14	15,75	230	65	4	3,5	2,7
20	50	58	42,9	75	69,9	105	100	62	125	G1/8	12	34,5	14	15,75	260	75	4	9	3,4
25	50	68	50,8	85	79,4	115	110	62	130	G1/8	16	34,5	14	15,75	260	85	4	15	4,1
	80	68	50,8	85	79,4	115	110	98	170	G1/4	16	55	14	15,75	260	85	4	17	5,7
32	50	78	63,5	100	88,9	140	115	62	145	G1/8	16	34,5	18	15,75	300	100	4	21	5,7
	80	78	63,5	100	88,9	140	115	98	185	G1/4	20	55	18	15,75	300	100	4	24	7,2
	125	78	63,5	100	88,9	140	115	146	215	G1/4	20	80	18	15,75	300	100	4	24	9,4
40	50	88	73	110	98,4	150	125	62	150	G1/8	16	34,5	18	15,75	300	110	4	30	6,4
	80	88	73	110	98,4	150	125	98	190	G1/4	23	55	18	15,75	300	110	4	37	7,9
	125	88	73	110	98,4	150	125	146	220	G1/4	23	80	18	15,75	300	110	4	37	10
50	50	102	92,1	125	120,7	165	150	62	160	G1/8	16	34,5	18	19,05	350	125	4	40	8,6
	80	102	92,1	125	120,7	165	150	98	195	G1/4	29	55	18	19,05	350	125	4	58	10,1
	125	102	92,1	125	120,7	165	150	146	225	G1/4	29	80	18	19,05	350	125	4	58	12,5
65	80	122	104,8	145	139,7	185	180	98	215	G1/4	29	55	18	19,05	400	125	8/4	80	13,9
	125	122	104,8	145	139,7	185	180	146	245	G1/4	29	80	18	19,05	400	125	8/4	80	14,6
80	125	138	127	160	152,4	200	190	146	252	G1/4	29	80	18	19,05	450	125	8/4	80	16,63

Angle Seat Valve 7031

reinforced design

Dimensions and Weights

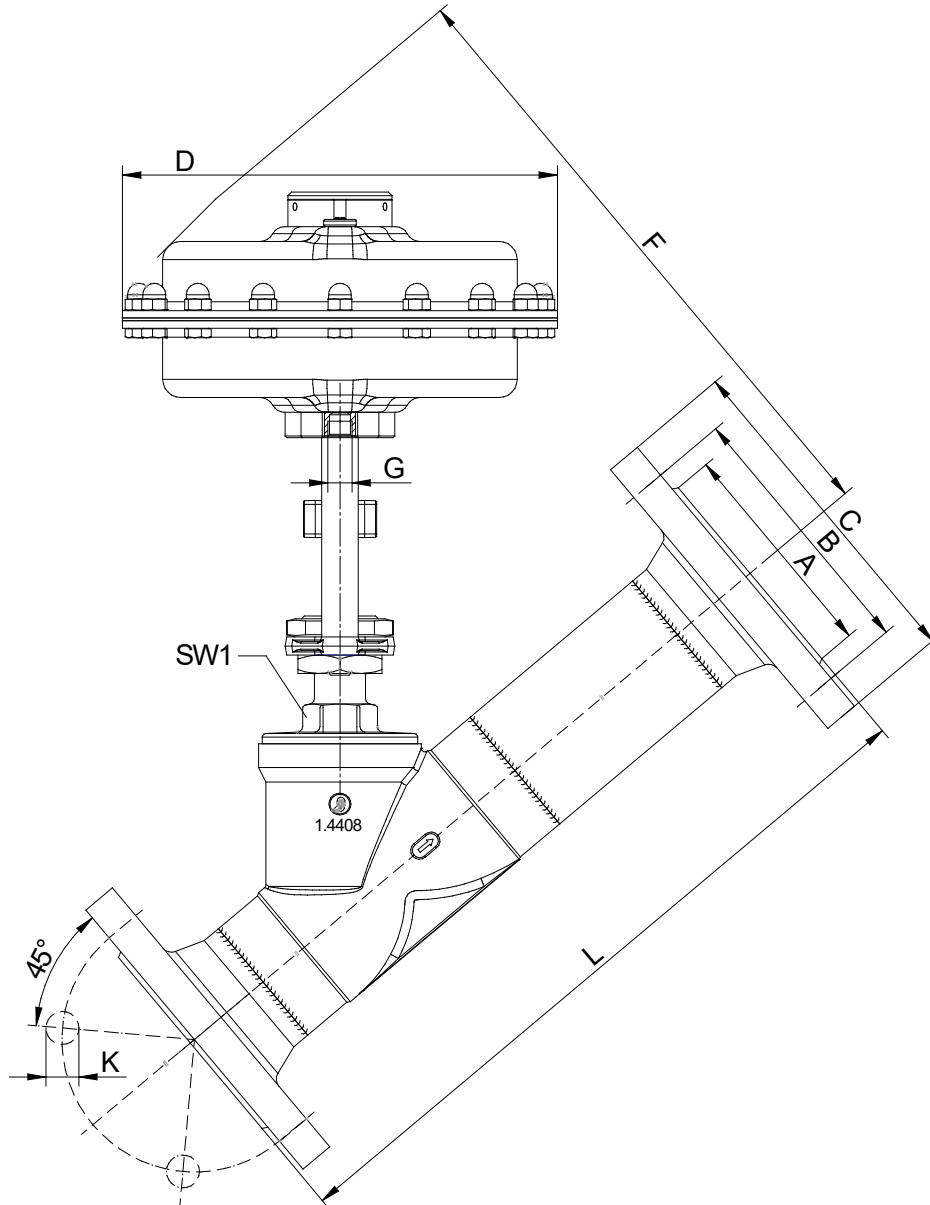

PN40

Size	Piston Ø	A	B	C	D	K	number of borings	L	G	F	SW1	F		Kvs- value	Weight (kg)
												SW1	pressure balanced		
50	250	102	125	165	146	18	4	350	G1/4	337	32	342	52	58	20,3
65	250	122	145	185	146	18	8	400	G1/4	345	41	359	36	80	23
80	250	138	160	200	146	18	8	450	G1/4	450	41	416	46	112	23

ANSI150

Size	Piston Ø	A	B	C	D	K	number of borings	L	G	F	SW1	F		Kvs- value	Weight (kg)
												SW1	pressure balanced		
50	250	92	121	152	146	19	4	350	G1/4	337	32	342	52	58	20,3
65	250	107	140	178	146	19	4	400	G1/4	345	41	359	36	80	23
80	250	127	152	191	146	19	4	450	G1/4	450	41	416	46	112	23

Dimensions in mm

Angle Seat Valve 7031

pressure balanced version

Build up, dimensions and weight

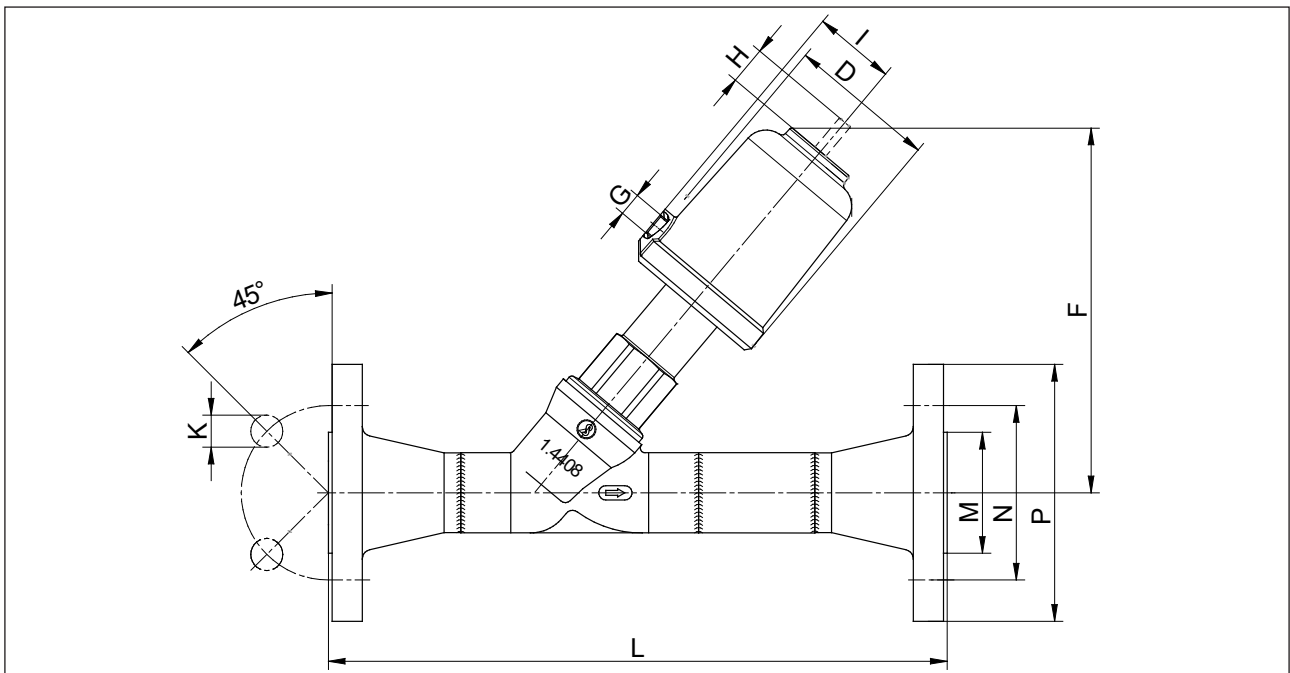
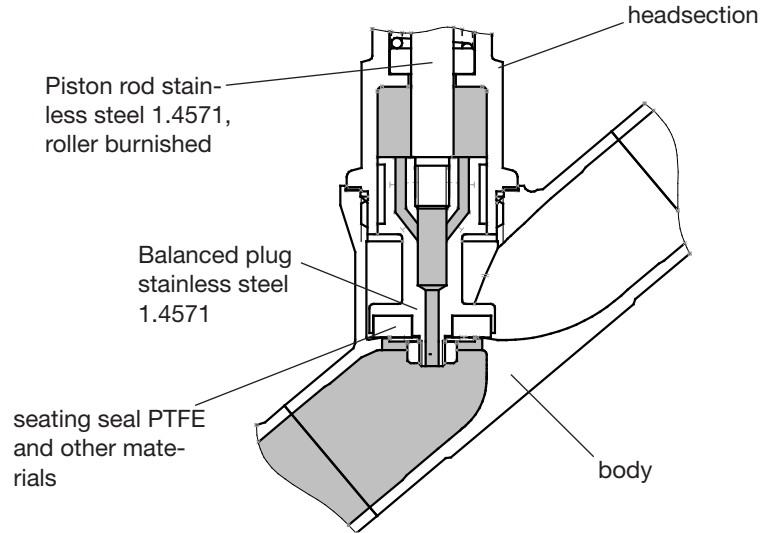

DN	Piston Ø	D	PN40				ANIS150				L	number of borings	I	F	G	H (stroke)
			M	N	P	K	M	N	P	K						
32	D50	62	78	100	140	18	63,5	88,9	115	15,88	300	4	34,5	165	G1/8"	16
	D80	96	78	100	140	18	63,5	88,9	115	15,88	300	4	55	205	G1/4"	16
40	D50	62	88	110	150	18	73	98,4	125	15,88	300	4	34,5	175	G1/8"	16
	D80	96	88	110	150	18	73	98,4	125	15,88	300	4	55	210	G1/4"	21
50	D50	62	88	120	165	18	92.1	120,7	150	19,05	350	4	34,5	180	G1/8"	16
	D80	96	102	125	165	18	92.1	120,7	150	19,05	350	4	55	220	G1/4"	22
	D125	146	102	125	165	18	92.1	120,7	150	19,05	350	4	80	245	G1/4"	22
65	D50	62	122	145	185	18	104.8	139,7	180	19,05	400	8/4	34,5	200	G1/8"	16
	D80	96	122	145	185	18	104.8	139,7	180	19,05	400	8/4	55	240	G1/4"	29
	D125	146	122	145	185	18	104.8	139,7	180	19,05	400	8/4	80	265	G1/4"	29
80	D80	96	138	160	200	18	127	152,4	190	19,05	450	8/4	55	271	G1/4"	29
	D125	146	138	160	200	18	127	152,4	190	19,05	450	8/4	80	296	G1/4"	29

Dimensions in mm

Dimensions and weight

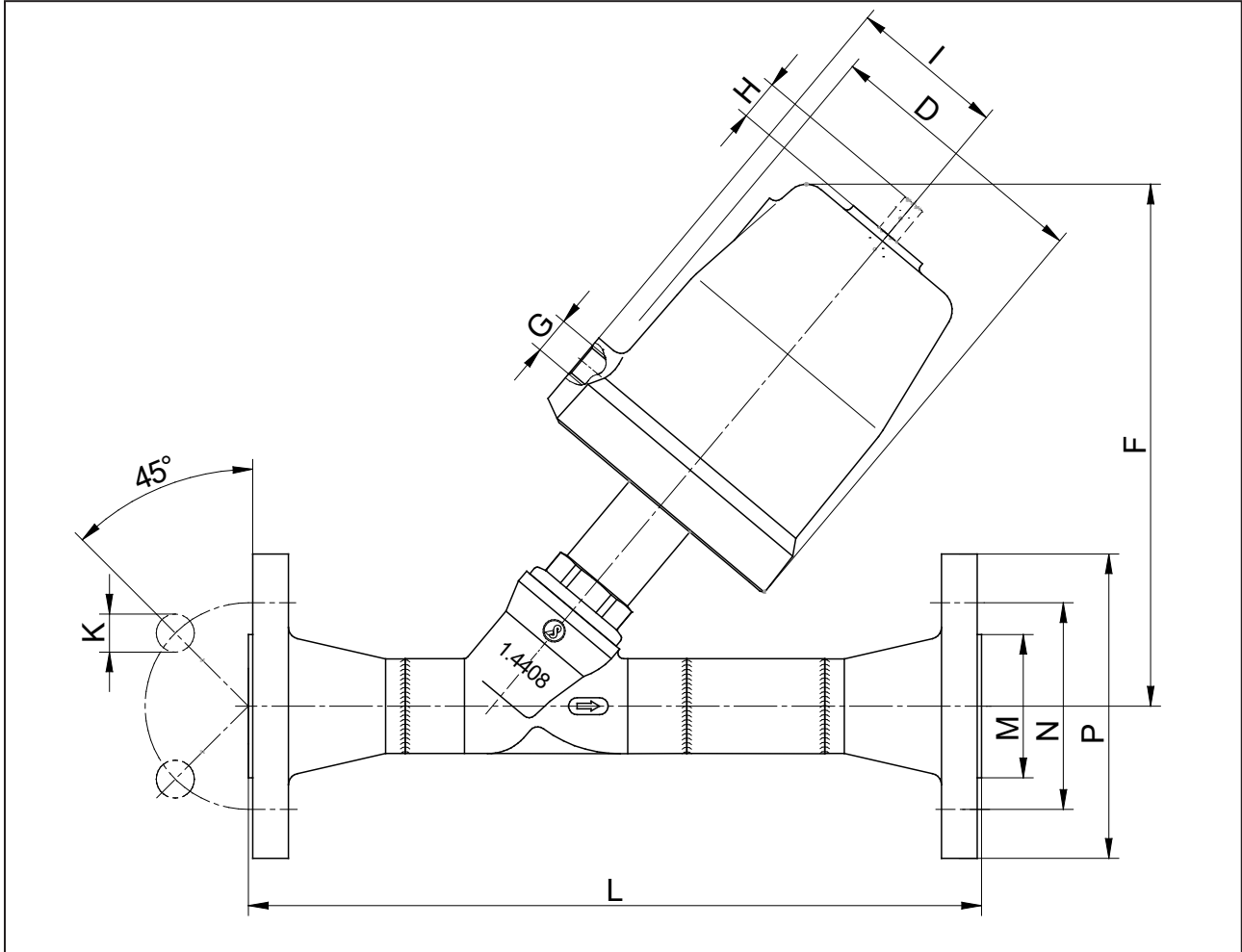

DN	Piston Ø	PN40				ANIS150				number of borings	F	L*
		M	N	P	K	M	N	P	K			
15	D50	45	65	95	14	34,9	60,3	90	15,88	4	139	230
20	D50	58	75	105	14	42,9	69,9	100	15,88	4	144	260
	D80	58	75	105	14	42,9	69,9	100	15,88	4	181	260
25	D80	68	85	115	14	50,8	79,4	110	15,88	4	185	260
	D125	68	85	115	14	50,8	79,4	110	15,88	4	215	260
32	D80	78	100	140	18	63,5	88,9	115	15,88	4	201	300
	D125	78	100	140	18	63,5	88,9	115	15,88	4	231	300
40	D80	88	110	150	18	73,2	98,4	125	15,88	4	206	300
	D125	88	110	150	18	73,2	98,4	125	15,88	4	235	300
50	D80	102	125	165	18	92.1	120,7	150	19,05	4	213	350
	D125	102	125	165	18	92.1	120,7	150	19,05	4	242	350

Dimensions in mm

Angle Seat Valve 7031

Temperature versions

Version	Beschreibung	Fluid temperature	Ambient temperature
2	Standard - Stainless steel	-30°C up to +170°C	-15°C up to +60°C
3	HT220 - version, only with PEEK seating seal	+160°C up to +220°C	-15°C up to +100°C
4	High temperature version in stainless steel	-30°C up to +200°C	-15°C up to +100°C
7	Low temperature version acc. to drawing R0194 for stainless steel body	-50°C up to +135°C	-15°C up to +60°C
8	Low temperature version acc. to drawing R0188 for stainless steel body		-40°C up to +60°C
10	Low temperature version for stainless steel body	-40°C up to + 170°C	-15°C up to +60°C
12	Bonnet for actuator made of polymer for stainless steel body	-30°C up to +135°C	-15°C up to +60°C
14	Low temperature version with bonnet for actuator made of polymer and stainless steel body	-40°C up to +135°C	-15°C up to +60°C
16	Long head section (without bellows)	-70°C up to +200°C	-15°C up to +60°C
17	Long head section with bellows	-100°C up to +200°C	-15°C up to +60°C
19	Standard, stainless steel with seals from NBR	-30°C up to +170°C	-30°C up to +60°C
21	Low temperature version, seating seal made of NBR and stainless steel body	-40°C up to +170°C	-30°C up to +60°C
22	Diaphragm actuator D250	-30°C up to +200°C	-30°C up to +60°C
23	Low temperature version for diaphragm actuator D250	-40°C up to +200°C	-30°C up to +60°C