

Sliding Gate Valve 8020

GS 3 series - 1/2" up to 10"

Pneumatic Sliding Gate Valve for controlling and shutting off liquid and gaseous media for industrial applications

- Space saving wafer type construction
- Lowest possible weight
- Quiet operation
- Fast response time
- Control of high differential pressures with small actuators
- Greatly reduced energy consumption rates due to short stroke and low actuating forces
- High Cv-values
- Side mount positioners with various communication protocols including HART, Fieldbus and Device Net
- Meets the requirements of TA-Luft 2021



Technical Information

Body design	ANSI flange wafer (self-aligning) for flanges acc. ASME B16.5 RF or DIN EN 1092-1 Form B		
Nominal sizes	1/2" up to 10"		
Nominal pressure acc. EN 1333	PN 40 (fits also to PN 10 - PN 25) PN 100 PN 16	1/2" - 6" 1/2" - 3" 8" - 10"	
Nominal pressure acc. ANSI	ANSI 150 ANSI 300 ANSI 600	1/2" - 10" 1/2" - 6" 1/2" - 3"	
Nominal pressure acc. JIS for flanges with raised face	10K 20K	1/2" - 2" 1/2" - 1 1/2"	
Supply air pressure	max. 90 psi		
Media temperature	Versions from -76°F up to 662°F		
Flange gaskets (customer side)	ANSI B16.21 or DIN EN 1514-1 in the respective nominal pressure rating		
Ambient temperature*	-22°F up to +212°F -58°F up to +212°F		
Rangeability / characteristic	40 : 1 linear / 80 : 1 equal percentage		
Leakage **	Disc pair Carbon-stainless steel	Disc pair SFC	Disc pair STN 2
% of Kvs	< 0,0001	< 0,0005	< 0,001
IEC 60534-4	IV-S1	IV-S1	IV
EN 12266-1	E	F	F
Marking ATEX non electric	II 2G Ex h IIC T6...T1 X Gb II 2D Ex h IIIC 85°C...530°C X Db		
Specific leakage rate shaft and body sealing	ISO FE - BH - CC3 - SSA0 - t (-40°C / +350 °C) - PN40 - ISO 15848-1		

* Please consider the limitation of use of the positioner!

** With size 1/2" with reduction of less than 25%, different leakage rates possible.
Kvs-values see data sheet 8001.

Fluid temperature

Rating	PN40	PN 16	PN 100	ANSI 150	ANSI 300	ANSI 600
Body material cpl. stainless steel						
Tmin [°F]	-76	-76	-76	-20	-20	-20
Tmax [°F]	662	662	662	662	662	662
Body material carbon steel with stainless steel body cover						
Tmin [°F]	-76	-76	14	-4	-4	-4
Tmax [°F]	662	662	662	662	662	662

Sliding Gate Valve 8020-GS3

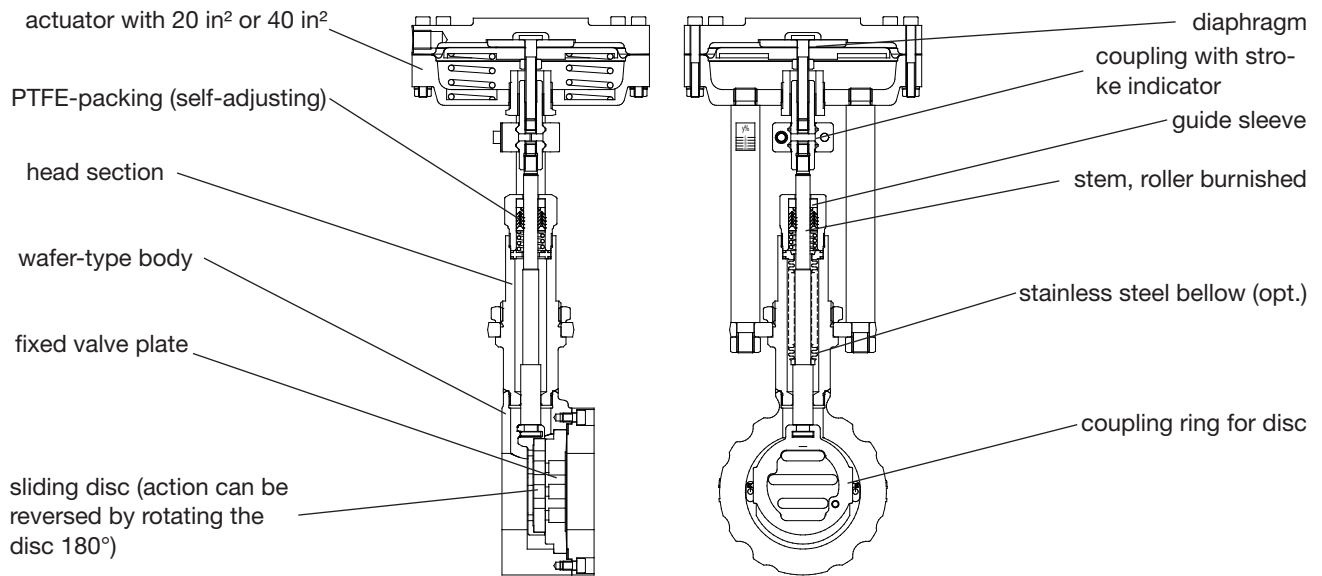

Admissible Pressures
(For temperatures of up to 100°F for ANSI-classes and up to 250°F for PN-classes)

For temperatures exceeding 100°F (ANSI) or 250°F (PN): consider operation limits

**Disc pair: carbon - stainless steel coated
SFC - stainless steel coated**

Diaphragm area	20 in ²					40 in ²				
	3 to 15	15 to 29	22 to 44	26 to 55	30 to 65	3 to 15	12 to 20	17 to 32	20 to 39	25 to 46
Spring range (psi)	3 to 15	15 to 29	22 to 44	26 to 55	30 to 65	3 to 15	12 to 20	17 to 32	20 to 39	25 to 46
Supply air (psi)	17	41	61	75	87.0	17	30	46	58	67
Size	Admissible differential pressures in psi									
1/2"	65	1480	1480	1480	1480	275	1480	1480	1480	1480
3/4"	55	1480	1480	1480	1480	240	1480	1480	1480	1480
1"	45	1276	1276	1276	1276	200	1276	1276	1276	1276
1 1/4"	40	(1450)*	(1450)*	(1450)*	(1450)*	165	(1450)*	(1450)*	(1450)*	(1450)*
1 1/2"	30,0	955	1276	1276	1276	125	1276	1276	1276	1276
2"	-	520	(1450)*	(1450)*	(1450)*	85	(1450)*	(1450)*	(1450)*	(1450)*
2 1/2"	-	420	825	1015	1220	70	915	1405	1480	1480
3"	-	245	655	810	970	45	740	1130	1160	1160
4"	-	145	375	480	565	-	435	655	695	695
5"	-	95	230	290	350	-	260	390	480	480
6"	-	75	145	190	220	-	175	260	320	335
8"	-	35	110	130	160	-	125	190	230	230
10"	-	25	65	80	95	-	75	110	130	145
Spring configuration	-	40	50	60	60	-	30	70	85	95
Spring configuration	Code D	Code 2	Code 3	Code 4	Code 5	Code D	Code 2	Code 3	Code 4	Code 5

Standard

*: figures in brackets for bodys of carbon steel

	Pressure limits ANSI and DIN in psi					
	ANSI150	ANSI 300	ANSI 600	PN16	PN40	PN100
P max. carbon steel	284	741	1480	232	580	1450
P max. stainless steel	276	719	1440			

Disc pair: STN 2

Diaphragm area	20 in ²					40 in ²				
	3 to 15	15 to 29	22 to 44	26 to 55	30 to 65	3 to 15	12 to 20	17 to 32	20 to 39	25 to 46
Spring range (psi)	3 to 15	15 to 29	22 to 44	26 to 55	30 to 65	3 to 15	12 to 20	17 to 32	20 to 39	25 to 46
Supply air (psi)	17	44	64	78	87	17	32	48	58	70
Size	Admissible differential pressures in psi									
1/2"	45	1480	1480	1480	1480	195	1480	1480	1480	1480
3/4"	35	825	1480	1480	1480	150	1480	1480	1480	1480
1"	25	825	1275	1275	1275	110	1275	1275	1275	1275
1 1/4"	20	(1480)*	(1480)*	(1480)*	(1480)*	85	(1480)*	(1480)*	(1480)*	(1480)*
1 1/2"	15	550	855	1060	1260	55	955	1480	1480	1480
2"	-	335	535	655	785	35	595	915	1045	1045
2 1/2"	-	190	290	365	435	30	335	510	610	710
3"	-	145	230	290	350	15	260	405	495	580
4"	-	85	130	160	205	-	145	230	275	335
5"	-	50	80	100	125	-	95	145	175	205
6"	-	35	50	65	80	-	60	95	115	130
8"	-	20	35	50	60	-	45	65	80	95
10"	-	15	25	30	25	-	25	40	50	55
Spring configuration	Code D	Code 2	Code 3	Code 4	Code 5	Code D	Code 2	Code 3	Code 4	Code 5

Standard

*: figures in brackets for bodys of carbon steel

The supply air pressure stated in the table is the minimum supply air pressure that has to be available. This is valid for use without a positioner. When utilizing a positioner the required supply air pressure is determined by the adjustment of the positioner. For the standard version it is 60 psi. The spring configuration „D“ allows the usage of a control valve without a positioner but with limited performance. The valve can be controlled directly by a process controller with a signal of 3 to 15 psi.

Application limitations for GS3 valves in stainless steel

These pressure must not be exceeded for GS-valves from the GS3-series made of stainless steel, even though the actuator power might allow it.

ANSI150

Size	Sliding unit: carbon/SFC - stainless steel, coated								Sliding unit: STN2							
	max. admissible pressures for GS3-valves in stainless steel								max. admissible pressures for GS3-valves in stainless steel							
	100°F	120°F	210°F	300°F	390°F	480°F	570°F	660°F	100°F	120°F	210°F	300°F	390°F	480°F	570°F	660°F
1/2" - 5"	275	265	235	215	200	175	150	120	275	265	235	215	200	175	150	120
6"	230	230	230	215	200	175	150	120	235	235	235	215	200	170	140	120
8"	230	230	230	215	200	175	150	120	150	145	120	110	100	80	65	55
10"	150	150	150	145	135	120	105	100	-	-	-	-	-	-	-	-

Limitation for SFC-sliding discs: 570°F

ANSI300

Size	Sliding unit: carbon/SFC - stainless steel, coated								Sliding unit: STN2							
	max. admissible pressures for GS3-valves in stainless steel								max. admissible pressures for GS3-valves in stainless steel							
	100°F	120°F	210°F	300°F	390°F	480°F	570°F	660°F	100°F	120°F	210°F	300°F	390°F	480°F	570°F	660°F
1/2" - 2 1/2"	720	695	610	560	520	485	460	440	720	695	610	560	520	485	460	440
3"	695	695	610	560	520	485	460	440	530	530	530	505	480	390	320	275
4"	480	480	480	480	480	480	460	440	480	480	480	460	435	355	290	250
5"	335	335	335	335	335	335	335	335	320	320	320	305	290	235	190	165
6"	230	230	230	230	230	230	230	230	230	230	230	225	210	170	140	120
8"	230	230	230	145	135	120	105	100	230	230	220	200	180	155	140	130

Limitation for SFC-sliding discs: 570°F

ANSI600

Size	Sliding unit: carbon/SFC - stainless steel, coated								Sliding unit: STN2							
	max. admissible pressures for GS3-valves in stainless steel								max. admissible pressures for GS3-valves in stainless steel							
	100°F	120°F	210°F	300°F	390°F	480°F	570°F	660°F	100°F	120°F	210°F	300°F	390°F	480°F	570°F	660°F
1/2" - 3/4"	1440	1395	1225	1115	1035	970	915	880	1440	1395	1225	1115	1035	970	915	880
1"	1275	1275	1225	1115	1015	925	830	785	1275	1275	1225	1115	1015	925	830	785
1 1/4"	1440	1395	1225	1115	1035	970	915	880	1440	1395	1225	1115	1035	970	915	875
1 1/2"	1275	1275	1225	1115	1015	925	830	785	1050	1050	1050	1000	950	770	630	545
2"	1440	1395	1225	1115	1035	970	915	880	1125	1125	1125	1070	1020	825	675	585
2 1/2"	1160	1160	1160	1115	1035	970	915	880	905	905	605	865	820	665	545	470
3"	695	695	695	695	695	695	695	645	530	530	530	505	480	390	320	275

Limitation for SFC-sliding discs: 570°F

PN40

Size	Sliding unit: carbon/SFC - stainless steel, coated							Paarung: STN 2					
	maximum pressures for GS3-valves in stainless steel							maximum pressures for GS3-valves in stainless steel					
	210°F	300°F	390°F	480°F	570°F	660°F		210°F	300°F	390°F	480°F	570°F	660°F
1/2"-1 1/4"	580	580	580	580	580	580		580	580	580	580	580	580
1 1/2"	580	580	580	580	580	580		580	580	580	580	580	535
2"	580	580	580	580	580	580		580	580	580	580	580	580
2 1/2"	580	580	580	580	580	580		580	580	580	580	535	465
3"	580	580	580	580	580	580		520	495	480	375	320	275
4"	480	480	480	480	480	480		465	450	435	350	290	245
5"	335	335	335	335	335	335		305	305	275	230	190	160
6"	230	230	230	230	230	230		220	220	205	160	130	115
8" (only PN16)	230	230	220	190	175	160		120	110	100	80	65	55
10" (only PN16)	145	130	130	115	100	85		-	-	-	-	-	-

Limitation for SFC-sliding discs: 570°F

PN100

Size	Sliding unit: carbon/SFC - stainless steel, coated							Paarung: STN 2					
	maximum pressures for GS3-valves in stainless steel							maximum pressures for GS3-valves in stainless steel					
	210°F	300°F	390°F	480°F	570°F	660°F		210°F	300°F	390°F	480°F	570°F	660°F
1/2"	1450	1450	1450	1350	1220	1145		1450	1450	1450	1350	1220	1145
3/4"	1450	1450	1290	1175	1060	985		1450	1450	1290	1175	1060	985
1"	1275	1175	1015	915	825	785		1275	1175	1015	915	825	785
1 1/4"	1450	1350	1160	1060	945	900		1450	1350	1160	1060	945	870
1 1/2"	1275	1175	1015	915	825	785		1045	1000	945	770	625	535
2"	1450	1450	1450	1450	1450	1365		1115	1060	1015	810	665	580
2 1/2"	1160	1160	1160	1145	1030	970		900	855	810	655	535	465
3"	695	695	695	695	695	640		520	495	480	375	320	275

Limitation for SFC-sliding discs: 570°F

Application limitations for GS3 valves in carbon steel

These pressure must not be exceeded for GS-valves from the GS3-series made of carbon steel, even though the actuator power might allow it.

ANSI150

Size	Sliding unit: carbon/SFC - stainless steel, coated								Sliding unit: STN2							
	max. admissible pressures for GS3-valves in carbon steel								max. admissible pressures for GS3-valves in carbon steel							
	100°F	120°F	210°F	300°F	390°F	480°F	570°F	660°F	100°F	120°F	210°F	300°F	390°F	480°F	570°F	660°F
1/2"-5"	285	280	255	230	200	175	150	120	285	280	255	230	200	175	150	120
6"	230	230	230	230	200	175	150	120	235	235	235	225	200	170	140	115
8"	230	230	230	230	200	175	150	120	150	145	120	110	100	65	65	55
10"	150	150	150	145	135	120	105	87	-	-	-	-	-	-	-	-

Limitation for SFC-sliding discs: 570°F

ANSI300

Size	Sliding unit: carbon/SFC - stainless steel, coated								Sliding unit: STN2							
	max. admissible pressures for GS3-valves in carbon steel								max. admissible pressures for GS3-valves in carbon steel							
	100°F	120°F	210°F	300°F	390°F	480°F	570°F	660°F	100°F	120°F	210°F	300°F	390°F	480°F	570°F	660°F
1/2"-2"	740	725	675	655	635	610	565	535	740	725	675	655	635	610	565	535
2 1/2"	740	725	675	655	635	610	565	535	605	605	605	575	545	485	550	470
3"	695	695	675	655	635	610	565	535	530	530	530	505	480	390	319	275
4"	480	480	480	480	480	480	475	475	480	480	480	460	435	355	290	245
5"	335	335	335	335	335	335	330	330	320	320	320	305	290	235	191	155
6"	230	230	230	230	230	230	230	230	230	230	230	225	210	170	141	115
8"	230	230	220	200	180	155	140	130	150	145	120	110	100	65	65	55

Limitation for SFC-sliding discs: 570°F

ANSI600

Size	Sliding unit: carbon/SFC - stainless steel, coated								Sliding unit: STN2							
	max. admissible pressures for GS3-valves in carbon steel								max. admissible pressures for GS3-valves in carbon steel							
	100°F	120°F	210°F	300°F	390°F	480°F	570°F	660°F	100°F	120°F	210°F	300°F	390°F	480°F	570°F	660°F
1/2"-1"	1480	1455	1350	1310	1270	1215	1155	1085	1480	1455	1350	1310	1270	1215	1155	1085
1 1/4"	1480	1455	1350	1310	1270	1215	1155	1085	1480	1455	1350	1310	1270	1215	1010	870
1 1/2"	1450	1450	1350	1310	1270	1215	1155	1085	1050	1050	1050	1000	950	770	630	535
2"	1450	1450	1350	1310	1270	1215	1155	1085	1125	1125	1125	1070	1020	825	675	580
2 1/2"	1160	1160	1160	1160	1160	1160	1155	1085	905	905	905	865	820	665	545	460
3"	695	695	695	695	695	695	695	635	530	530	530	535	480	390	320	275

Limitation for SFC-sliding discs: 570°F

PN40

Size	Sliding unit: carbon/SFC - stainless steel, coated							Sliding unit: STN2					
	max. admissible pressures for GS3-valves in carbon steel							max. admissible pressures for GS3-valves in carbon steel					
	210°F	300°F	390°F	480°F	570°F	660°F	210°F	300°F	390°F	480°F	570°F	660°F	
1/2" - 2"	580	580	580	580	580	580	580	580	580	580	580	580	
2 1/2"	580	580	580	580	580	580	580	580	580	580	535	460	
3"	580	580	580	580	580	580	520	495	480	375	320	275	
4"	480	480	480	480	480	475	480	450	435	350	290	245	
5"	335	335	335	335	335	330	320	305	275	230	190	155	
6"	230	230	230	230	230	230	230	220	205	160	130	115	
8" (only PN16)	230	230	220	190	175	155	120	110	100	80	65	55	
10" (only PN16)	145	130	130	115	100	87	-	-	-	-	-	-	

Limitation for SFC-sliding discs: 570°F

PN100

Size	Sliding unit: carbon/SFC - stainless steel, coated							Sliding unit: STN2					
	max. admissible pressures for GS3-valves in carbon steel							max. admissible pressures for GS3-valves in carbon steel					
	210°F	300°F	390°F	480°F	570°F	660°F	210°F	300°F	390°F	480°F	570°F	660°F	
1/2" - 3/4"	1450	1450	1450	1450	1450	1450	1450	1450	1450	1450	1450	1450	
1"	1450	1450	1450	1450	1365	1260	1450	1450	1450	1450	1365	1260	
1 1/4"	1450	1450	1450	1450	1450	1435	1450	1450	1450	1220	1000	870	
1 1/2"	1450	1450	1450	1450	1365	1260	1045	1000	945	770	625	535	
2"	1450	1450	1450	1450	1450	1360	1115	1060	1015	810	665	580	
2 1/2"	1160	1160	1160	1160	1160	1100	900	855	810	655	535	460	
3"	695	695	695	695	695	635	520	495	480	375	320	275	

Limitation for SFC-sliding discs: 570°F

Dimensions and Weights

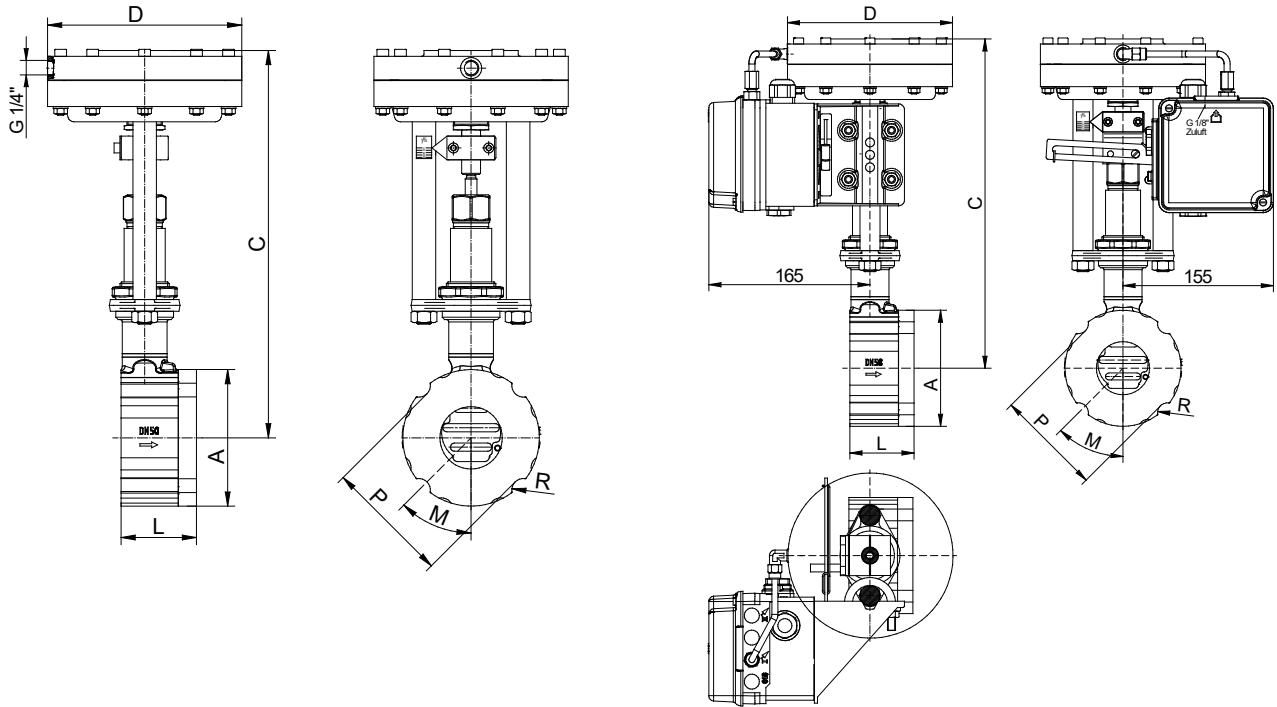

with side-mount positioner

Size	A	C	Ø D actuator size		L	Weight lbs actuator size		Stroke
			20 in ²	40 in ²		20 in ²	40 in ²	
1/2"	2.5	12	6.5	8.75	2.2	14.3	19.1	0.24
3/4"	2.85	12.2	6.5	8.75	2.2	14.7	19.6	0.24
1"	3.25	12.4	6.5	8.75	2.2	15.8	20.7	0.24
1 1/4"	3.5	12.6	6.5	8.75	2.2	16.5	21.3	0.24
1 1/2"	3.9	12.8	6.5	8.75	2.2	17.6	22	0.24
2"	4.55	13.2	6.5	8.75	2.5	20.9	26.4	0.31
2 1/2"	5.45	13.6	6.5	8.75	2.7	25.3	30.8	0.31
3"	6	14	6.5	8.75	2.75	27.5	33	0.31
4"	7.25	14.35	6.5	8.75	2.95	34.1	39.6	0.33
5"	8.35	14.95	6.5	8.75	3.15	40.7	46.2	0.33
6"	9.55	15.55	6.5	8.75	3.15	48.4	52.8	0.33
8"	11.9	16.75	6.5	8.75	3.65	85.8	90.2	0.33
10"	14.15	17.7	6.5	8.75	3.8	97.9	102.3	0.33

Dimensions in inch

Sliding Gate Valve 8020-GS3



Flow Coefficients - Cv-values

Ordering code	-	A	1	B	6	2	7	C	3	4	8	5	9	
Size	Charact.	100 %	63 %	40 %	25 %	20%	16 %	12 %	10 %	6,3 %	2,5 %	2 %	1 %	0,4%
1/2"	(mod.) linear	4.6	3	2	1.6	-	0.82	0.57	0.51	0.3	0.16	0.09	0.05	0.021
	eq. perc.	2	-	1.3	-	0.4	-	-	-	0.12	-	-	-	-
3/4"	(mod.) lin.	7.4	-	-	-	-	1.16	-	-	-	-	0.15	-	-
	eq. perc.	3.5	-	1.7	-	-	-	-	-	-	-	-	-	-
1"	(mod.) linear	13	7.4	4.6	-	-	1.9	-	1.08	0.72	0.3	-	0.16	0.05
	eq. perc.	5.8	-	2.8	-	1.3	-	-	-	0.41	-	-	-	-
1 1/4"	(mod.) linear	19	12	-	-	-	-	-	-	-	-	-	-	-
	eq. perc.	9.3	5.45	-	-	-	-	-	-	-	-	-	-	-
1 1/2"	(mod.) lin.	30	19	13	8.1	-	-	-	-	-	-	-	-	-
	eq. perc.	13	9.9	-	3.2	-	-	-	-	-	-	-	-	-
2"	(mod.) linear	52	32	23	14	12	-	-	-	-	-	-	-	-
	eq. perc.	22	14	-	-	-	3.5	-	-	-	-	-	-	-
2 1/2"	(mod.) linear	60	41	-	17	-	-	-	-	-	-	-	-	-
	eq. perc.	35	-	-	9.3	-	-	-	-	-	-	-	-	-
3"	(mod.) linear	107	67	46	-	-	-	-	-	-	-	-	-	-
	eq.perc.	56	41	-	-	-	-	-	-	-	-	-	-	-
4"	(mod.) linear	179	110	72	-	-	-	-	-	-	-	-	-	-
	eq.perc.	89	56	-	-	-	-	-	-	-	-	-	-	-
5"	(mod.) linear	275	-	110	-	-	-	-	-	-	-	-	-	-
	eq.perc.	135	-	-	-	-	-	-	-	-	-	-	-	-
6"	(mod.) linear	392	246	-	-	-	-	-	-	-	-	-	-	-
	eq.perc.	171	104	-	-	-	-	-	-	-	-	-	-	-
8"	(mod.) linear	650	408	-	-	-	-	-	-	-	-	-	-	-
	eq.perc.	329	-	-	-	-	-	-	-	-	-	-	-	-
10"	(mod.) linear	1056	667	-	-	-	-	-	-	-	-	-	-	-
	eq.perc.	-	-	-	-	-	-	-	-	-	-	-	-	-

Text and pictures are not binding. We reserve the right, to alter the equipment.