

Compact digital positioner for pneumatic control valves.

- Direct „top-mounted“ attachment to the valve drive. This means that no parts of the stroke return are accessible from the outside.
- Large stroke range 3 - 28 mm, optionally up to 50 mm.
- Reverse hysteresis of up to 0.2% possible, standard 0.4%
- Configuration adjustment through self-adaption
- Configuration and diagnostic functions via „DeviceConfig“ software
- Low vibration sensitivity
- Protection class IP 65
- On request also available in version for Ex zone 22
- Available with integrated process controller
- Also for rotary actuators (single or double-acting)
- Low air consumption in the regulated state
- Also available with IO-Link version



ATEX-Versions:



ATEX

II 2G Ex ia IIC T4 Gb für Typ 8049-ExPro-1
II 1G Ex ia IIC T4 Ga für Typ 8049-ExPro-0



APPROVED

IS.CL.I, DIV.1, GPA,B,C,D T4 entity
CL.I, Zone0, AEx ia IIC T4 entity
Zone0 Ex ia IIC T4 entity
OR
NI, CL.I, DIV.2, GPA,B,C,D T4 NIFW

Technical Information, standard versions

Version	8049-4**	8049-2	8049-ExPro / 8049-ExPro-FM
Nominal stroke	0.12 - 1.1 inch (optional up to 2 inch)	0.16 - 1.1 inch (optional up to 2 inch)	0.16 - 1.1 inch (optional up to 2 inch)
Voltage of the working resistance	2.5 V (125Ω@20mA)	6.5 V (325Ω@20mA)	8V (400Ω@20mA)
Supply air	max. 85 psi	max. 85 psi	max. 90 psi
Unrestricted air capacity *	40 NI/min	24 NI/min	24 NI/min
Stationary air consumption *	< 0,06 NI/min	< 0,4 NI/min	< 0,4 NI/min
Leakage	< 0,01 NI/min		
Ambient temperature	14 up to +167°F	+14 up to +167°F	+14 up to +167°F
Control signal	0/4 - 20 mA opt. 0/2 - 10 V	4 - 20 mA	4 - 20 mA EX ***
Auxiliary energy, electric	24 VDC max 10 W	none	none
Adjustment of stroke and zero point	self-learning		
Configuration	with PC-Software		
Air quality according ISO 8573-1:			
max. particle size and density:	Class 5	Class 3	Class 3
oil content	Class 4	Class 2	Class 2
pressure dew point	Class 3	Class 3	Class 3
	min. 20K (36°F) under ambient temperature		
Actuation gas	compressed air or non flammable gases (nitrogen, CO ₂ ,...)		
Mounting to control valve	standardized mounting kits (also with optical position indicator)		
Pressure supply port	G 1/8" NPT		
Max.connection section	1,5mm ²		
Protection class acc. DIN 40050	IP 65		

* at 73 psi pilot pressure

** from version 4P6

*** Follow instructions

Technical Information, ex-versions

Version	8049-ExPro-1	8049-ExPro-0	8049-ExPro-FM
	Use in Zone 1 and Zone 2	Use in Zone 0, Zone 1 and Zone 2	Use in Zone according FM label
General explosion-relevant information			
Applied standards	IEC 60079-0:2011, Ed. 6 IEC 60079-11:2011, Ed. 6		FM Class 3600 (2022) FM Class 3610 (2021) FM Class 3611 (2021) FM Class 3810 (2021) ANSI/ISA 61010-1 (82.02.01) (2012) ANSI/UL 61010-1 (2012) ANSI/UL 60079-0 (2019) ANSI/UL 60079-11 (2014) ANSI/UL 121201 (2017) ANSI/IEC 60529 (2013) CSA C22.2 No. 213 (2017) CAN/CSA-C22.2 No. 60079-0 (2019) CAN/CSA-C22.2 No. 60079-11 (2014) CAN/CSA C22.2 No. 60529 (2016) CAN/CSA C22.2 No. 61010-1 (2012)
Type examination certificate (ATEX)	BVS 17 ATEX E088		-
Type examination certificate (IEC)	IECEX BVS 17.0080		-
FM label	-	-	IS,CL.I, DIV.1, GPA,B,C,D T4 entity CL.I, Zone0, AEx ia IIC T4 entity Zone0 Ex ia IIC T4 entity OR NI, CL.I, DIV.2, GPA,B,C,D T4 NIFW
ATEX label	II 2G Ex ia IIC T4 Gb	II 1G Ex ia IIC T4 Ga	-
IEC label	Ex ia IIC T4 Gb	Ex ia IIC T4 Ga	-
Certificate number	-	-	FM22US0015 FM22CA0010
Temperature ranges	Tamb = 14 - 167°F		
Explosion-relevant information for control signal input (Terminals 1 and 2)			
Max. input voltage	Ui = DC 30V		
Max. input current	Ii = 120 mA		
Max. input power	Pi = 1000 mW		
Max. interior capacity	Ci = negligible		
Max. interior inductivity	Li = negligible		
Explosion-relevant information for alarm output (NAMUR EN 60947-5-6) (Terminals 3 and 4)			
Max. input voltage	Ui = DC 16V		
Max. input current	Ii = 25 mA		
Max. input power	Pi = 64 mW		
Max. interior capacity	Ci = 11 nF		
Max. interior inductivity	Li = negligible		
Explosion-relevant information for binary input (Terminals 5 and 6)			
Max. output voltage	Uo = DC 5,4V		
Max. output current	Io = 1 mA		
Max. output power	Po = 2 mW		
Max. external capacity	Co = 65 µF		
Max. external inductivity	Lo = 50 mH		
Explosion-relevant information for PC-COM			
Nominal output voltage	2,8V		
Max. output voltage	Um = 6,1 V		
Restriction	The interface may only be used for configuration provided that there is no explosive atmosphere.		
Explosion-relevant information for the external path sensor (version with Plug 4)			
Max. output voltage	Uo = 5,4 V		
Max. output current	Io = 66 mA		
Max. output power	Po = 89 mW		
Max. external capacity	Co = 59,5 µF		
Max. external inductivity	Lo = 8 mH		

Combination possibilities

	8049-4 (4-wire) version V6	8049-2 (2-wire) version V7	8049-ExPro (ex-version) version V3	8049-IPC with integrated process controller	8049-ExPro-FM
Standard body	x	x	x	x	
Ground plate in stainless steel	x	x	x	x	x
Positioner completely in stainless steel	x	x	x		x
Positioner for part turn actuator single acting	x	x	x	x	x
Positioner for part turn actuator double acting	x			x	
positioner for 50 mm stroke	x	x	x		
Feed back module RM-4		x	x		x
Feed back module RM-5	x				
gauge block	x	x	x	x	

Accessories

Analogue feedback modules

- Feedback on current valve position
- Feedback signal does not require calibration
- Easy to retrofit

Analogue feedback module RM-4 for 8049-2 , 8049-ExPro and 8049-ExPro-FM

- Feedback for 2 wire design and ExPro
- 2 limit signal transmitters according NAMUR (EN60947-5-6)
- Limit signal transmitters freely adjustable (0-100%) with software „DeviceConfig“

Technical Information

Output signal / Feedback	4 - 20 mA
Internal load	< 8V (400 Ω)
Temperature range	14 ... +167°F
Accuracy Feedback	± 1,5%
Limit signal transmitters	2 pieces
Switching range	adjustable 0-100%
Switching hysteresis	ca. 2.5%
Signal admissible deviation Actual value/setpoint	±2%

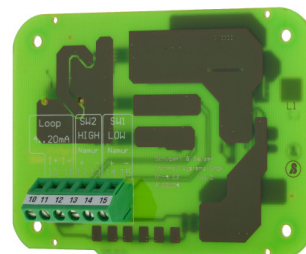

The following values must be observed for the RM-4 in connection with the 8049-ExPro

Limit switch according to NAMUR

Nominal voltage	DC 8.2 V
Maximum input voltage	Ui / Vmax = DC 16 V
Maximum input current	Ii / Imax = 25 mA
Maximum input power	Pi / Pmax = 64 mW
Maximum internal capacitance	Ci = 11 nF
Maximum internal inductance	Li = negligible
Galvanically isolated	

Feedback Output (Loop) 4...20 mA:

Nominal voltage range	DC 8...30 V
Nominal current range	3...25 mA
Maximum input voltage	Ui / Vmax = DC 30 V
Maximum input current	Ii / Imax = 120 mA
Maximum input power	Pi / Pmax = 1W
Maximum internal capacitance	Ci = negligible
Maximum internal inductance	Li = negligible
Galvanically isolated	

Analogue feedback module RM-5 for 8049-4

- Feedback for 4 wire design from version V6
- 2 electrically isolated limit signal transmitters
- Limit signal transmitters freely adjustable (0-100%) via Software DeviceConfig
- Binary input 24V

Technical Information

Supply voltage	24V DC (±10%)
Output signal	4 - 20 mA
Max. adm. working resistance	500 Ohm
Temperature range	14 ... +167°F
Limit signal transmitters	2 pieces
Switching range	adjustable 0-100%
Switching capacity of the limit sign.trans.	24V AC/DC , 70mA
Switching hysteresis	ca. 2.5%
Signal admissible deviation Actual value/setpoint	±2%
Switching threshold binary input	~12V

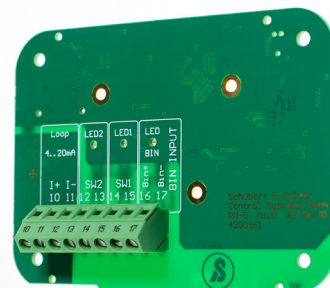

Accessories

Gauge Block

- Gauge block between positioner and connection block
- Pressure range 0 - 87 psi (0 - 6 bar)
- Easy field retrofit



Optical position indication for quarter-turn actuators



Housing Versions

Standard version

Ground plate in stainless steel

Completely stainless steel



Materials

	standard version	version „ground plate in stainless steel“	version „completely stainless steel“
positioner housing	Vestamid (electroconductive)	Vestamid (electroconductive)	stainless steel
ground plate	Aluminium, KTL-coated	stainless steel	stainless steel

Dimensions

For linear actuators

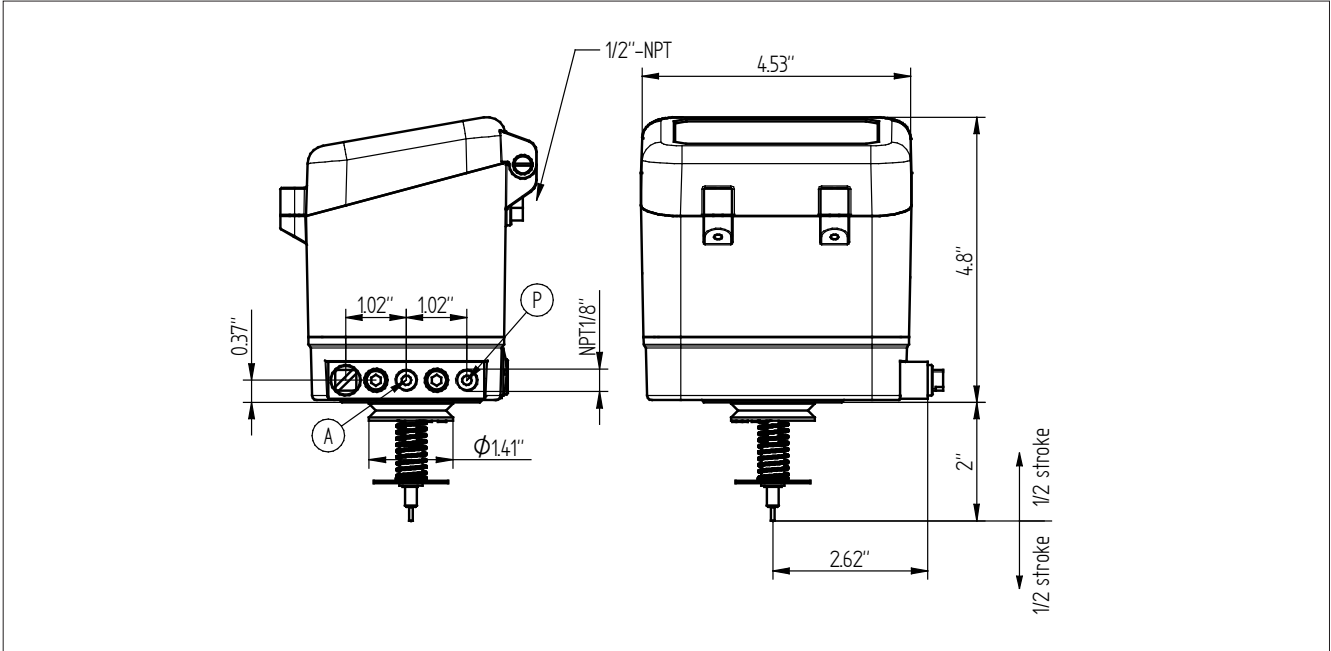

For quarter-turn actuators

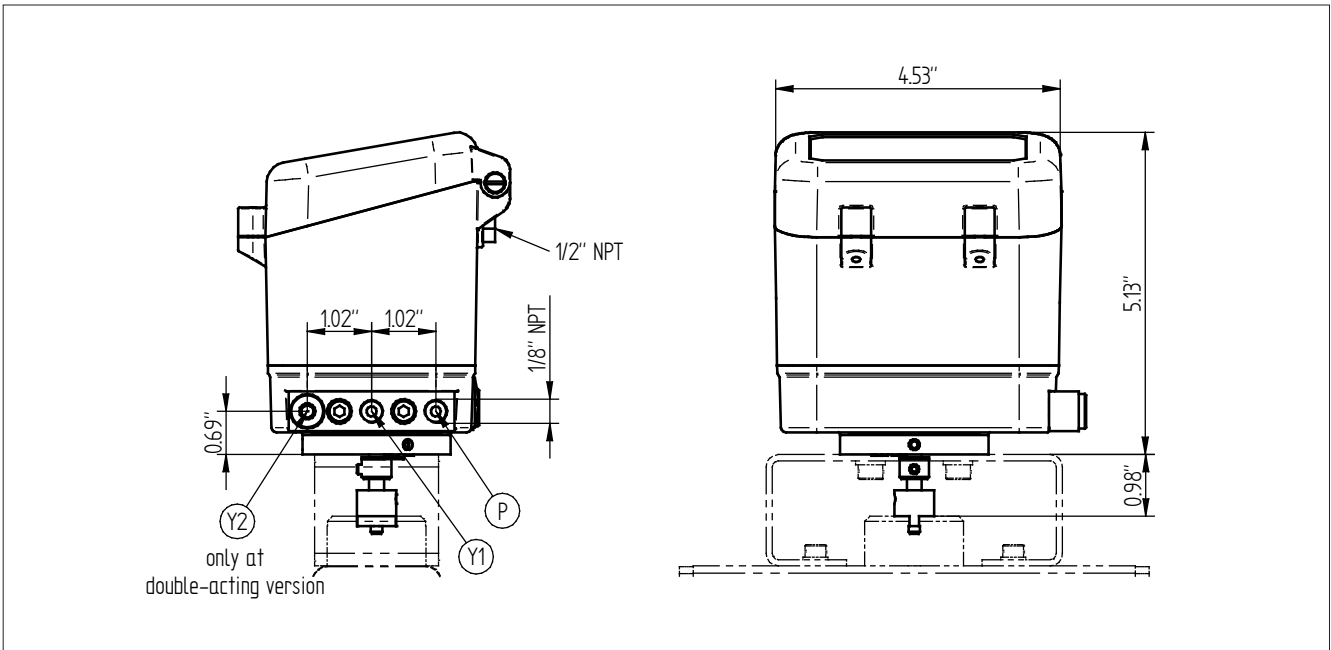

Configuration-Software „DeviceConfig“

Setup-Parameters

Adjustment of control parameters (input signal, stroke limitation, closing function, control hysteresis, valve function, etc.)

Live-Monitor

The operating conditions of the positioner, can be viewed with the live monitor.

Configuration-Software „DeviceConfig“

Diagnostic data

Informations of valve stroke, running time, soft- and hardware-versions, achieved temperature- and stroke levels, error messages, number of cycles, operating hours...

Base	Maintenance 1	Maintenance 2	Way classes
Results of self adaption			
Valve stroke:	8,25 mm		
Mech. middle position:	58,58%		
Top:	72,33%		
Bottom:	44,84%		
Stroke time [filling]:	0,993s		
Stroke time [draining]:	1,684s		
Production information			
Serial number:	S080000090684262		
Test date:	15.10.2021		
Version information			
Software-Version:	01.00.0		
Hardware-Version:	HW011		
Bootloader information			
Article number:	4300455		
Bootloader type	8049-4L STM32L4-HW011		
Bootloader version	2.20 20210629		
Name:			

Back

Application example

Positioner 8049 top mounted on GS-Control Valve Model 8021



Positioner 8049 top mounted on Aseptic Right Angle Control Valve Model 6051 with stainless steel body



Text and pictures are not binding. We reserve the right, to alter the equipment.